

Most of the gas chromatographs manufactured by SRI that employ multi-port gas valves follow a standard gas line connection and flow path scheme that is specific to the user's application and/or dictated by the analytical test method. The majority of these gas valve schemes have been diagrammed and are included in the Injector and Gas Valves section of the unit's manual. The page header information will quickly identify the different application diagrams for the user's reference. In certain cases, the ten-port valve must be plumbed differently in order to perform a unique function as required by the user of the instrument. If manual entries have been made on this diagram page, the SRI gas chromatograph that accompanies this manual has been equipped with a ten port valve that has been custom-configured to the specifications of the user.

All custom plumbing of this ten-port valve will be documented on this page by the builder for the user's reference. Please note that there are TWO diagrams shown on this page. The first diagram represents the relationship between port connections and flow scheme when the valve is in the LOAD position (rotated counter-clockwise). The second diagram represents the relationship between port connections and flow scheme when the valve is in the INJECT position (rotated clockwise). These diagrams are applicable to both manually-operated valves and automated valves built into this chromatograph.

APPLICATION OF VALVE: \_\_\_\_\_

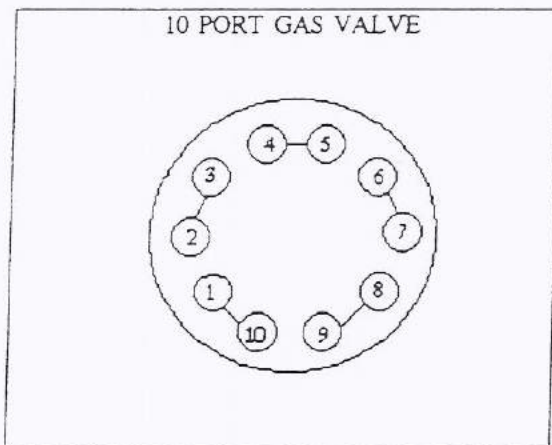

Valve in LOAD position

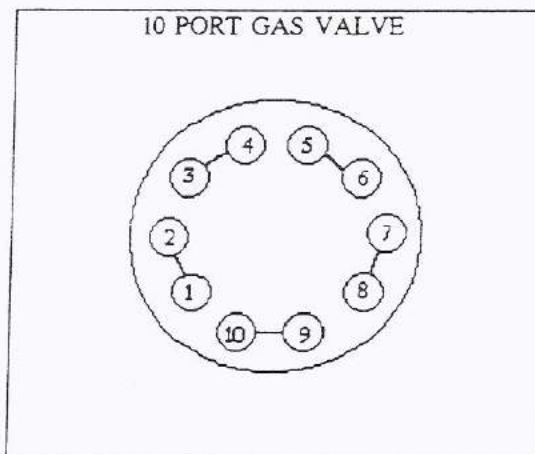

Valve in INJECT position

DESCRIPTION OF CONNECTIONS MADE AT EACH PORT OF GAS VALVE

- |         |          |
|---------|----------|
| 1 _____ | 6 _____  |
| 2 _____ | 7 _____  |
| 3 _____ | 8 _____  |
| 4 _____ | 9 _____  |
| 5 _____ | 10 _____ |

Most of the gas chromatographs manufactured by SRI that employ multi-port gas valves follow a standard gas line connection and flow path scheme that is specific to the user's application and/or dictated by the analytical test method. The majority of these gas valve schemes have been diagrammed and are included in this section of the unit's manual. The page header information will quickly identify the different application diagrams for the user's reference. In certain cases, the ten-port valve must be plumbed differently in order to perform a unique function as required by the user of the instrument. In some applications, dual valves are required and utilized. If manual entries have been made on this diagram page, the SRI gas chromatograph that accompanies this manual has been equipped with dual ten port valves that have been custom-configured to the specifications of the user.

All custom plumbing of these ten-port valves will be documented on this page by the builder for the user's reference. Please note that there are TWO diagrams shown on this page. The first diagram represents the relationship between port connections and flow scheme when the valves are in the LOAD position (rotated counter-clockwise). The second diagram represents the relationship between port connections and flow scheme when the valves are in the INJECT position (rotated clockwise). These diagrams apply to both manually-operated valves and automated valves built into this chromatograph.

APPLICATION OF VALVES: \_\_\_\_\_

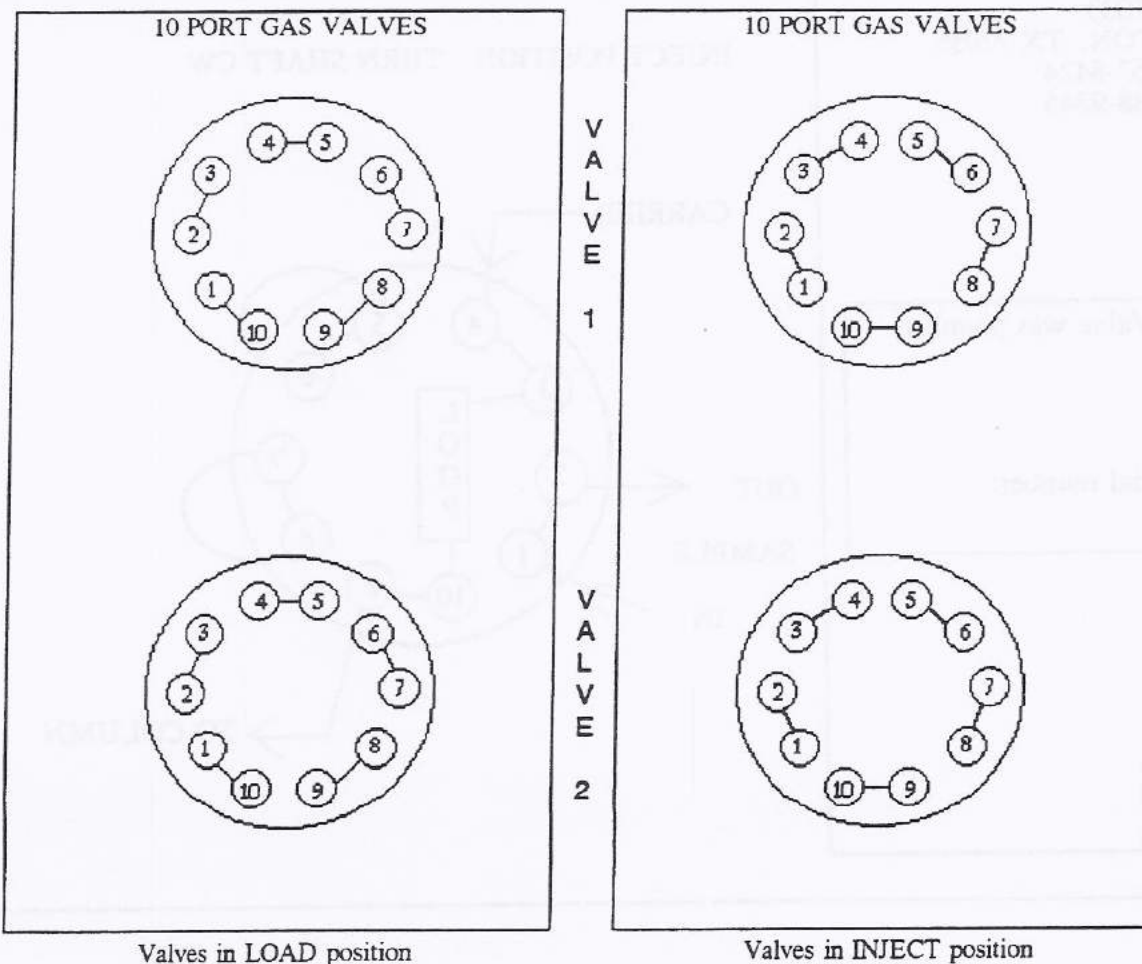

SRI has plumbed the valve in your GC according to the accompanying schematic.

In the LOAD position:

Carrier gas flows onto the column while sample gas flows through the sample loop.

In the INJECT position:

Carrier gas flows through the sample loop and then onto the column.

Valco's ten port valve catalog has a large assortment of plumbing applications. You can order Valco's catalog from:

VALCO  
 BOX 55603  
 HOUSTON, TX 77055  
 (800) 367-8424  
 (713) 688-9345

Your Valve was plumbed by:

Date:

GC serial number:

LOAD POSITION - TURN SHAFT CCW

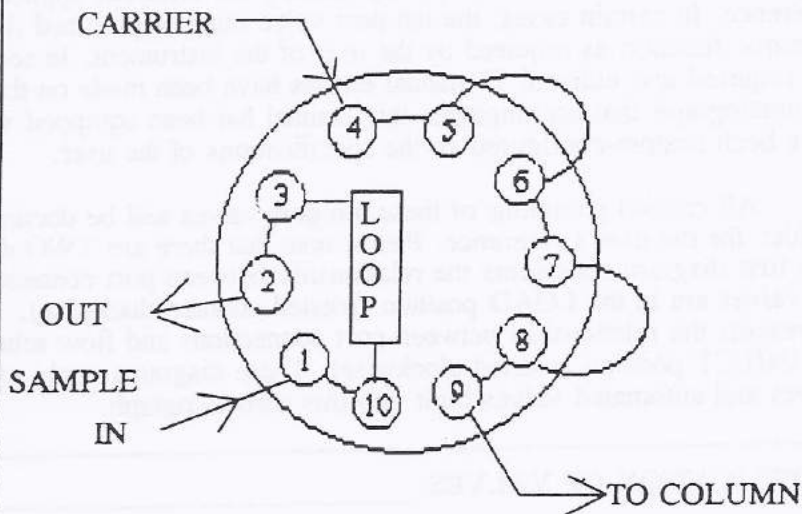

INJECT POSITION - TURN SHAFT CW

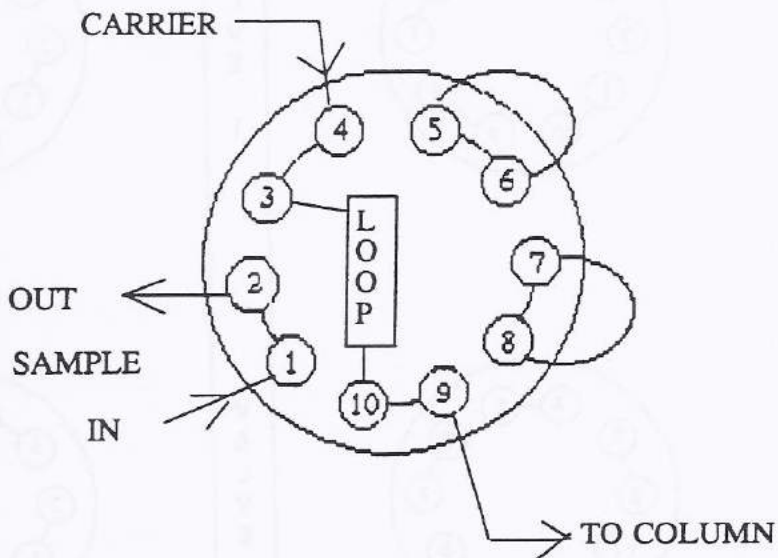

SRI has plumbed the valve in your GC according to the accompanying schematic.

In the LOAD position:

Sample loop A is in position to be loaded while sample loop B has carrier gas flowing through it onto the column.

In the INJECT position:

Sample loop B is in position to be loaded while sample loop A has carrier gas flowing through it onto the column.

Valco's ten port valve catalog has a large assortment of plumbing applications. You can order Valco's catalog from:

VALCO  
BOX 55603  
HOUSTON, TX 77055  
(800) 367-8424  
(713) 688-9345

Your Valve was plumbed by:

Date:

GC serial number:

LOAD POSITION - TURN SHAFT CCW

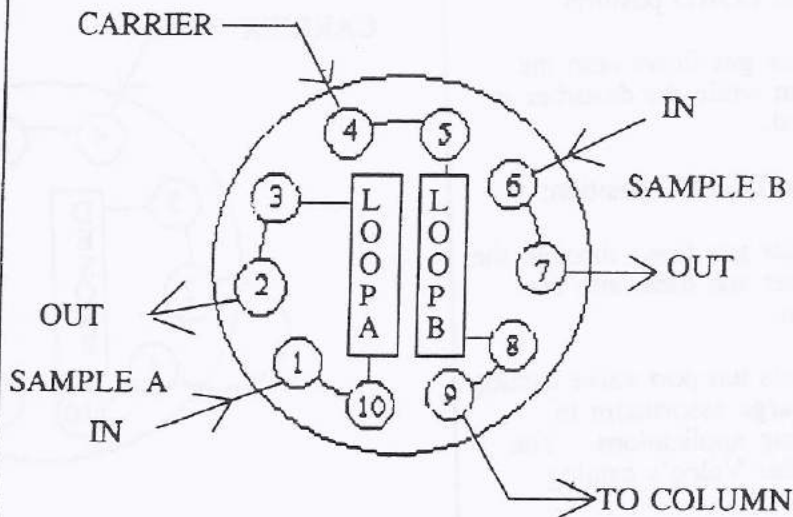

INJECT POSITION - TURN SHAFT CW

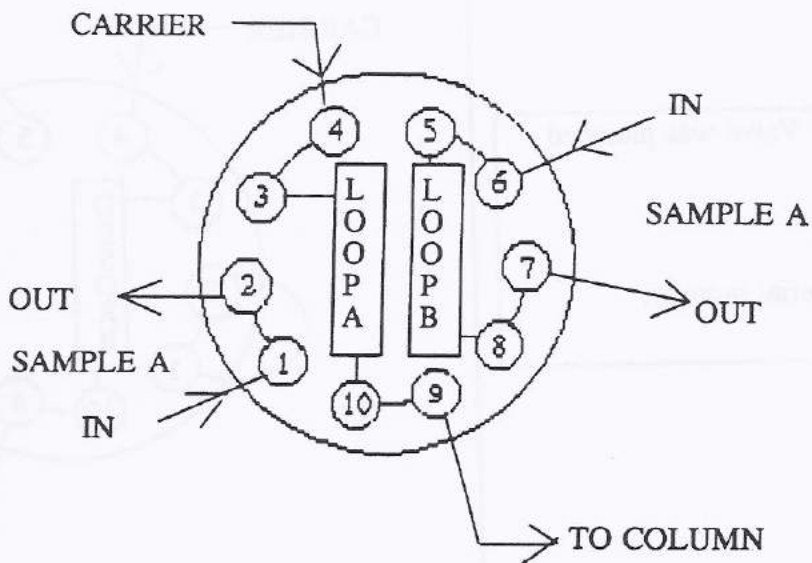

SRI has plumbed the valve in your GC according to the accompanying schematic.

In the LOAD position:

Carrier gas flows onto the column while the desorber is isolated.

In the INJECT position:

Carrier gas flows through the desorber and then onto the column.

Valco's ten port valve catalog has a large assortment of plumbing applications. You can order Valco's catalog from:

VALCO  
 BOX 55603  
 HOUSTON, TX 77055  
 (800) 367-8424  
 (713) 688-9345

Your Valve was plumbed by:

Date:

GC serial number:

LOAD POSITION - TURN SHAFT CCW

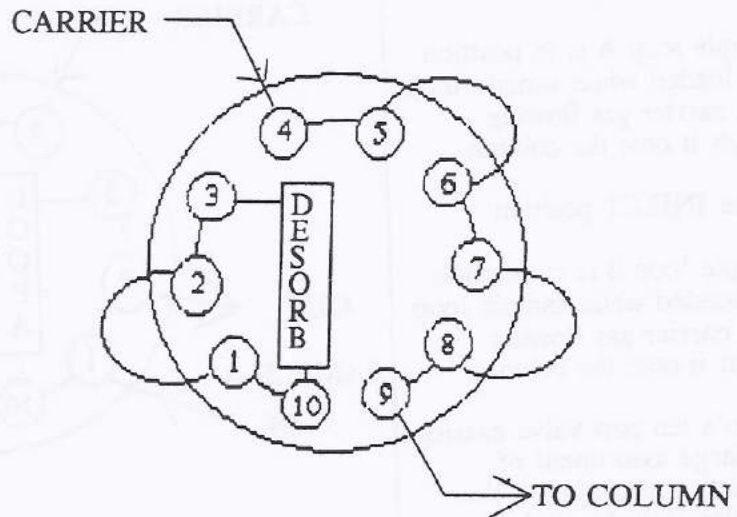

INJECT POSITION - TURN SHAFT CW

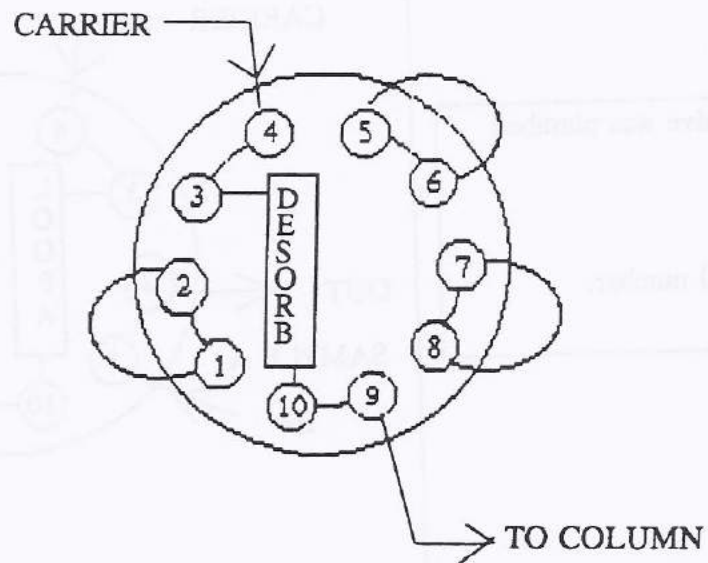

SRI has plumbed the valve in your GC according to the accompanying schematic.

In the LOAD position:

Both sample loops are in the load position while carrier A flows onto column A and carrier B flows onto column B.

In the INJECT position:

Carrier A flows through loop A onto column A while carrier B flows through loop B onto column B.

Valco's ten port valve catalog has a large assortment of plumbing applications. You can order Valco's catalog from:

VALCO  
BOX 55603  
HOUSTON, TX 77055  
(800) 367-8424  
(713) 688-9345

Your Valve was plumbed by:

Date:

GC serial number:

LOAD POSITION - TURN SHAFT CCW

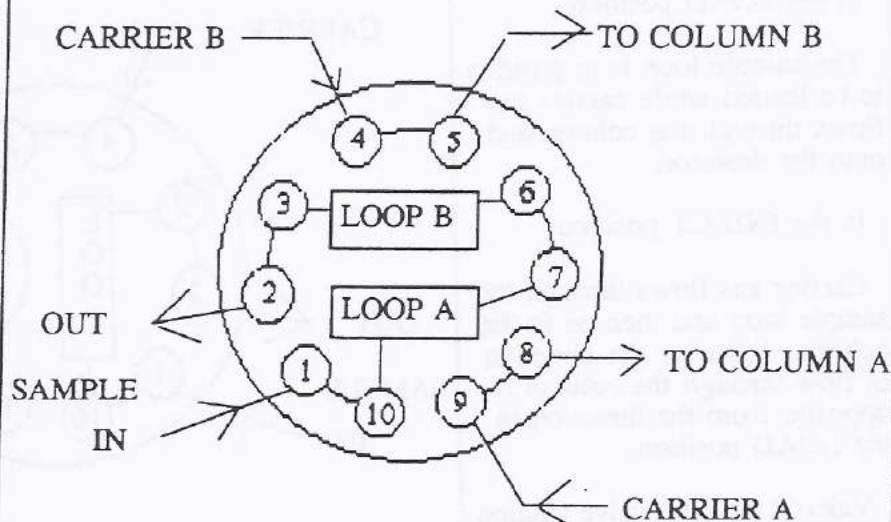

INJECT POSITION - TURN SHAFT CW

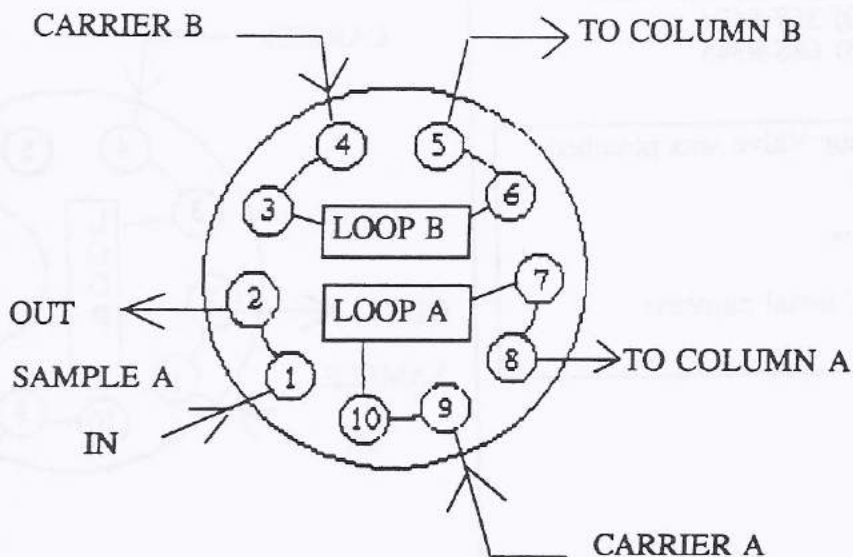

SRI has plumbed the valve in your GC according to the accompanying schematic.

In the LOAD position:

The sample loop is in position to be loaded while carrier gas flows through the column and onto the detector.

In the INJECT position:

Carrier gas flows through the sample loop and then on to the column, however the direction of flow through the column is opposite from the direction in the LOAD position.

Valco's ten port valve catalog has a large assortment of plumbing applications. You can order Valco's catalog from:

VALCO  
BOX 55603  
HOUSTON, TX 77055  
(800) 367-8424  
(713) 688-9345

Your Valve was plumbed by:

Date:

GC serial number:

LOAD POSITION - TURN SHAFT CCW

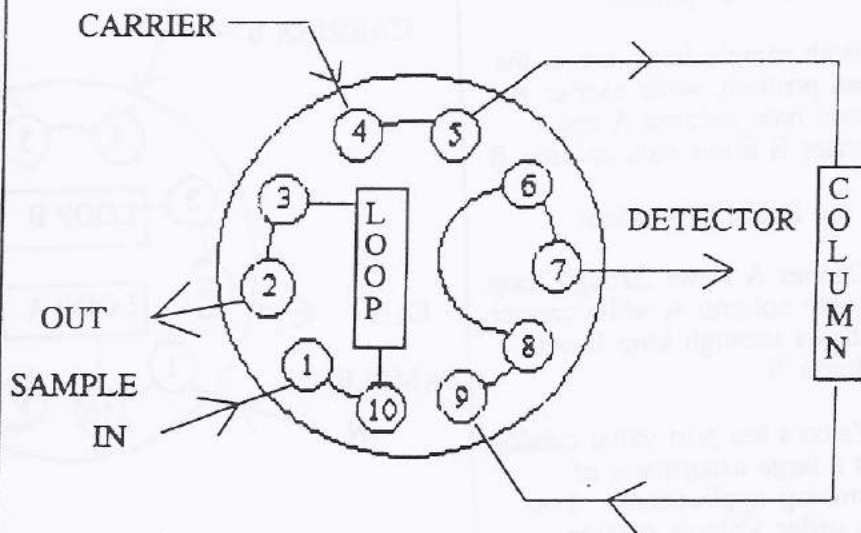

INJECT POSITION - TURN SHAFT CW

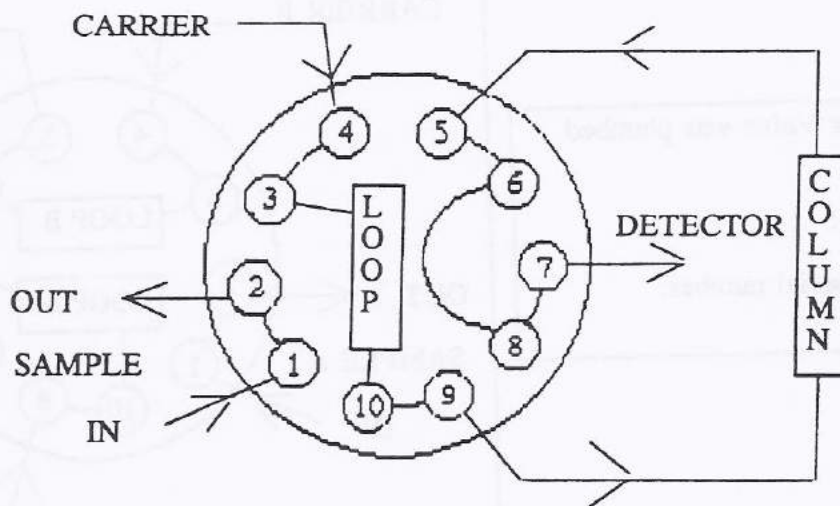

SRI has plumbed the valve in your GC according to the accompanying schematic.

In the LOAD position:

The sample loop is in position for loading. Column 1 has carrier flowing through and out the vent. Column 2 has flow from carrier 2.

In the INJECT position:

Carrier 2 is venting while carrier 1 flows through column 1 and 2. The direction of flow through column 1 in the INJECT position is reversed from the LOAD position.

Valco's ten port valve catalog has a large assortment of plumbing applications. You can order Valco's catalog from:

VALCO  
BOX 55603  
HOUSTON, TX 77055  
(800) 367-8424  
(713) 688-9345

Your Valve was plumbed by:

Date:

GC serial number:

LOAD POSITION - TURN SHAFT CCW

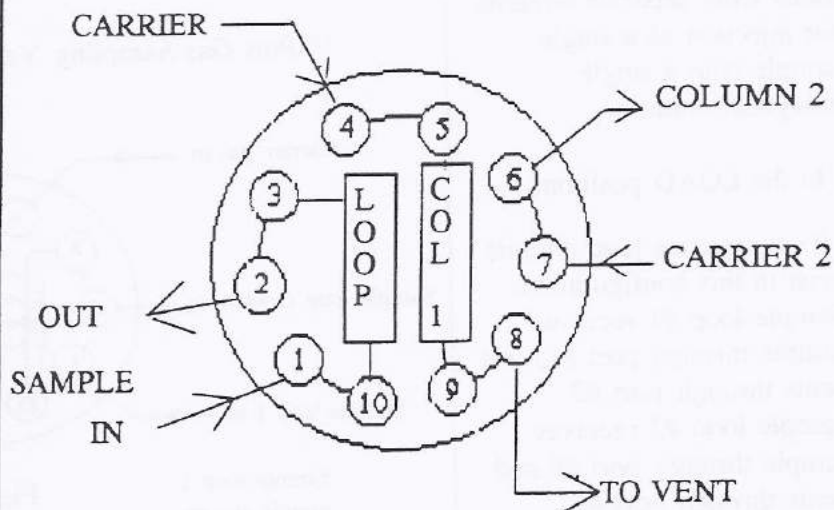

INJECT POSITION - TURN SHAFT CW

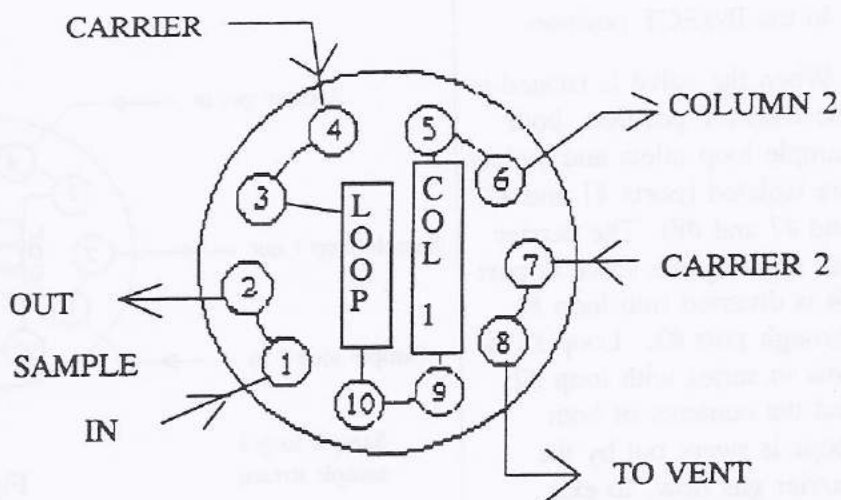



The following is a description of the 10 port gas sampling valve plumbed to permit the loading of dual loops from separate streams for injection as a single sample onto a single analytical column.

In the LOAD position:

Two separate loop circuits exist in this configuration. Sample loop #1 receives sample through port #1, and vents through port #2. Sample loop #2 receives sample through port #8 and vents through port #7. Meanwhile the carrier gas is routed into port #4 from the injector, through the valve, and out through port #5 to the analytical column and detector.

In the INJECT position:

When the valve is rotated to the INJECT position, both sample loop inlets and outlets are isolated (ports #1 and #2, and #7 and #8). The carrier gas entering the valve at port #4 is diverted into loop #1 through port #3. Loop #1 is now in series with loop #2 and the contents of both loops is swept out by the carrier gas flow, to exit through port #5 to the analytical column for analysis. At no time is the carrier gas flow to the column interrupted, protecting both the column and the detector.

This gas sampling valve configuration permits two separate loops to be loaded simultaneously from two streams and injected together onto the analytical column.

10 Port Gas Sampling Valve in LOAD Position

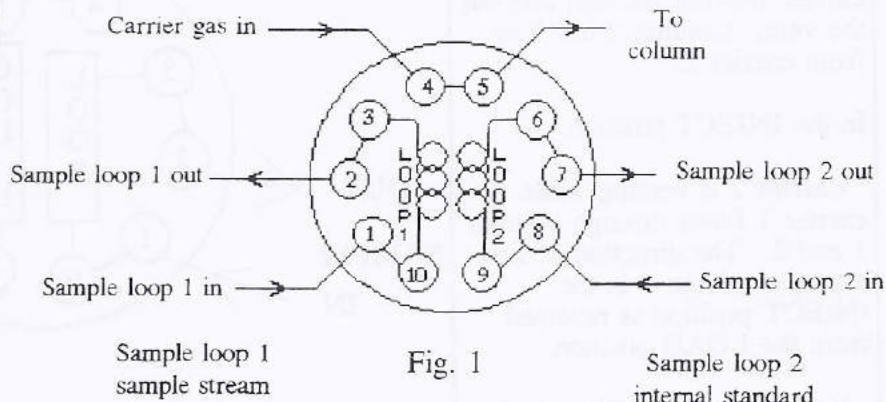

10 Port Gas Sampling Valve in INJECT Position

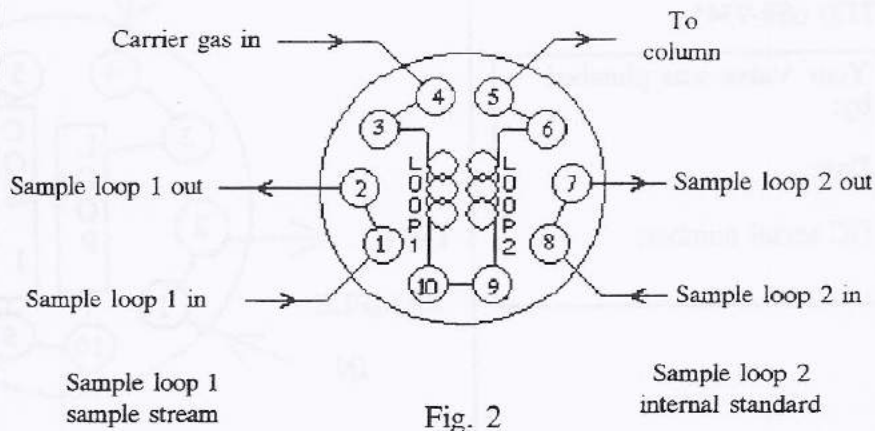

This configuration is convenient for applications where an internal standard must be inserted into the sample prior to analysis. Both samples are then merged and deposited on-column for analysis when the sampling valve is rotated to the INJECT position.

**Chapter:** INJECTORS & VALVES

**Topic:** Liquid and Loop Sampling with Backflush of Pre-column to Vent (Using External Liquid Sample Valve)

SRI has plumbed the valves in your GC according to the accompanying schematic.

In the LOAD position:

The liquid sample valve (LSV) is in position for loading while the gas sample valve is in inject position.

In the INJECT position:

Carrier gas flows through the liquid sample slot in LSV and the 10-port valve then on to the column.

The 10-port valve remains in the inject position throughout the injection procedure and then switches to load position for vent.

Valco's ten port valve catalogue has a large assortment of plumbing applications. You can order Valco's catalogue from:

VALCO  
BOX 55603  
HOUSTON, TX 77055  
(800) 367-8424  
(713) 688-9345

Your Valve was plumbed  
by:

Date:

GC serial number:

**LOAD POSITION**

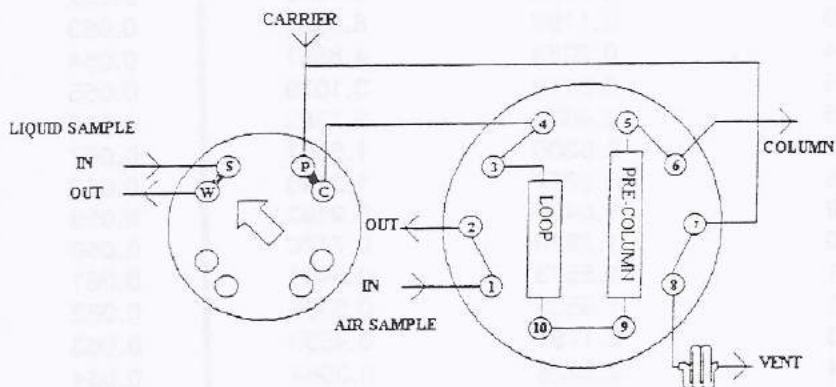

**INJECT POSITION**

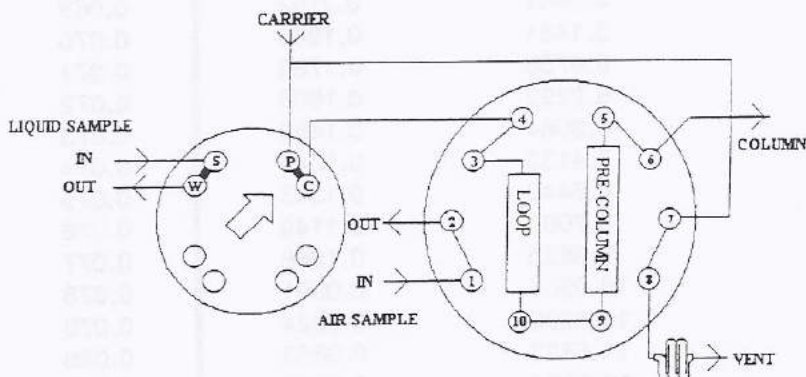

# TUBE VOLUME SELECTION GUIDE

INTERNAL DIAMETER	MICROLITERS PER INCH	INCHES PER MICROLITER	INTERNAL DIAMETER	MICROLITERS PER INCH	INCHES PER MICROLITER
0.001	0.0129	77.6979	0.051	33.4757	0.0299
0.002	0.0515	19.4245	0.052	34.8014	0.0287
0.003	0.1158	8.6331	0.053	36.1527	0.0277
0.004	0.2059	4.8561	0.054	37.5299	0.0266
0.005	0.3218	3.1079	0.055	38.9327	0.0257
0.006	0.4633	2.1583	0.056	40.3613	0.0248
0.007	0.6306	1.5857	0.057	41.8157	0.0239
0.008	0.8237	1.2140	0.058	43.2958	0.0231
0.009	1.0425	0.9592	0.059	44.8016	0.0223
0.010	1.2870	0.7770	0.060	46.3332	0.0216
0.011	1.5573	0.6421	0.061	47.8905	0.0209
0.012	1.8533	0.5396	0.062	49.4735	0.0202
0.013	2.1751	0.4598	0.063	51.0822	0.0196
0.014	2.5226	0.3964	0.064	52.7167	0.0190
0.015	2.8958	0.3453	0.065	54.3770	0.0184
0.016	3.2948	0.3035	0.066	56.0630	0.0178
0.017	3.7195	0.2689	0.067	57.7747	0.0173
0.018	4.1700	0.2398	0.068	59.5122	0.0168
0.019	4.6462	0.2152	0.069	61.2754	0.0163
0.020	5.1481	0.1942	0.070	63.0643	0.0159
0.021	5.6758	0.1762	0.071	64.8790	0.0154
0.022	6.2292	0.1605	0.072	66.7195	0.0150
0.023	6.8084	0.1469	0.073	68.5856	0.0146
0.024	7.4133	0.1349	0.074	70.4775	0.0142
0.025	8.0440	0.1243	0.075	72.3952	0.0138
0.026	8.7003	0.1149	0.076	74.3386	0.0135
0.027	9.3825	0.1066	0.077	76.3077	0.0131
0.028	10.0903	0.0991	0.078	78.3026	0.0128
0.029	10.8239	0.0924	0.079	80.3232	0.0124
0.030	11.5833	0.0863	0.080	82.3696	0.0121
0.031	12.3684	0.0809	0.081	84.4417	0.0118
0.032	13.1792	0.0759	0.082	86.5395	0.0116
0.033	14.0158	0.0713	0.083	88.6631	0.0113
0.034	14.8781	0.0672	0.084	90.8124	0.0110
0.035	15.7662	0.0634	0.085	92.9875	0.0108
0.036	16.6799	0.0600	0.086	95.1882	0.0105
0.037	17.6195	0.0568	0.087	97.4148	0.0103
0.038	18.5847	0.0538	0.088	99.6670	0.0100
0.039	19.5758	0.0511	0.089	101.9450	0.0098
0.040	20.5925	0.0486	0.090	104.2488	0.0096
0.041	21.6350	0.0462	0.091	106.5783	0.0094
0.042	22.7032	0.0440	0.092	108.9335	0.0092
0.043	23.7972	0.0420	0.093	111.3145	0.0090
0.044	24.9169	0.0401	0.094	113.7212	0.0088
0.045	26.0624	0.0384	0.095	116.1537	0.0086
0.046	27.2336	0.0367	0.096	118.6119	0.0084
0.047	28.4306	0.0352	0.097	121.0958	0.0083
0.048	29.6532	0.0337	0.098	123.6055	0.0081
0.049	30.9017	0.0324	0.099	126.1409	0.0079
0.050	32.1758	0.0311	0.100	128.7020	0.0078

## Overview

Built-in to the 8610C gas chromatograph, the SRI Purge & Trap is designed for compliance with EPA Methods 5030 and/or 5035 for the extraction of volatile organic compounds from water or soil samples. The purge and trap technique is applicable to a range of molecules from  $C_3$  to  $C_{12}$ . The Purge & Trap hardware consists of a 10 port valve in a heated, ducted valve oven, two traps, a cooling fan, and the purge head(s). The unique dual trap design enables the simultaneous trapping of compounds with different boiling points. Each trap has its own heater, and the ends of the traps are enclosed in the valve oven ducts to prevent cold spots. The cooling fan maintains the adsorption temperature and rapidly lowers trap heat after desorption. The trap in the lower position (TRAP 1) is usually packed with Tenax™-GR at the factory, while the upper trap (TRAP 2) is left empty for the user to pack with the desired adsorbent. A Carbosieve™ packed trap is also shipped with the GC for optional installation in the TRAP 2 position. The Carbosieve trap is used only when the analysis includes light gaseous VOC's, the most common being vinyl chloride. The Method 5030 Purge & Trap is the standard model with a fixed purge head that uses disposable 16mm test tubes for ambient temperature purging. There is a built-in septum port on this purge head through which gas standards may be spiked. The

Method 5030/5035 Purge & Trap features interchangeable purge heads. The 5035 purge head is a thermostatted heater body (from ambient to 50°C) which accepts standard 40mL VOA vials. Inside the heater body are two needles which puncture the septum: the longer one bubbles helium purge gas through the sample, while the shorter needle exhausts sample-laden gas to the adsorbent traps. In compliance with EPA Method 5035, the purge head is mechanically agitated while the sample is being purged. There is a syringe port on the Method 5030/5035 Purge & Trap that allows water and internal standard to be added to the sample in the vial without puncturing the septum again. Operation of the Purge & Trap is automated by the PeakSimple data system.

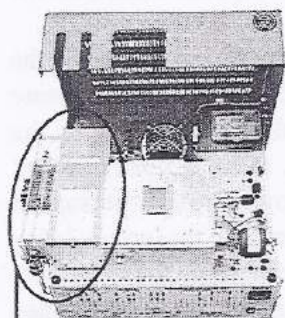

SRI GC equipped with Method 5030 Purge & Trap

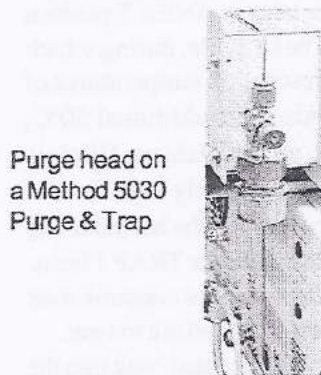

Purge head on a Method 5030 Purge & Trap

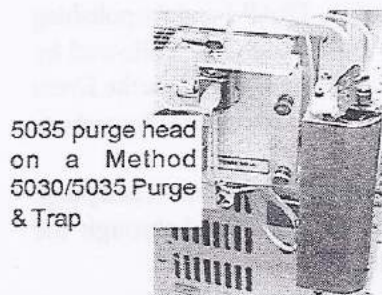

5035 purge head on a Method 5030/5035 Purge & Trap

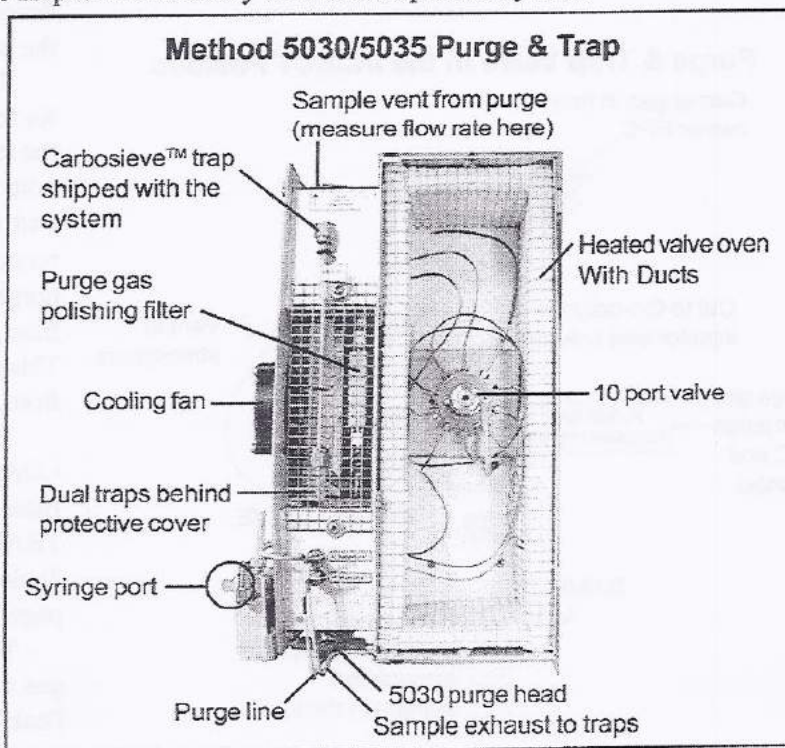

# INJECTORS

## Purge & Trap

### Theory of Operation

#### Purge & Trap Valve in the LOAD Position

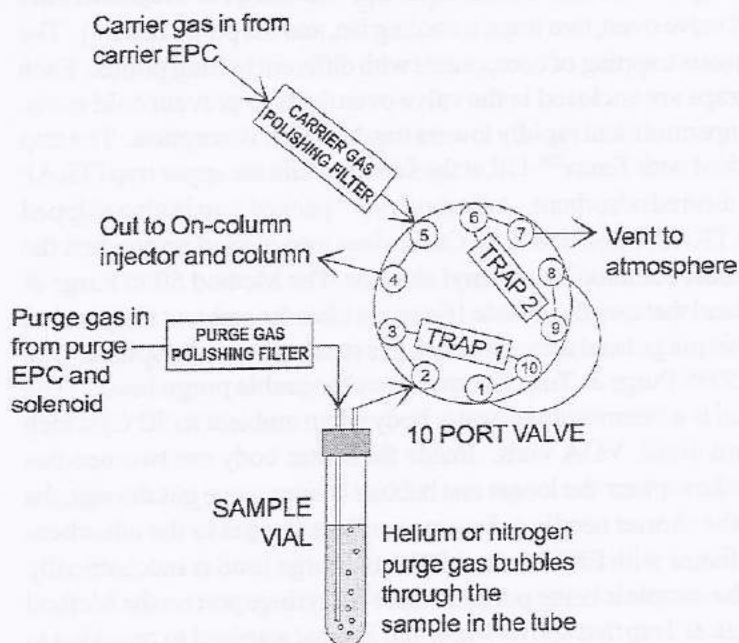

#### Purge & Trap Valve in the INJECT Position

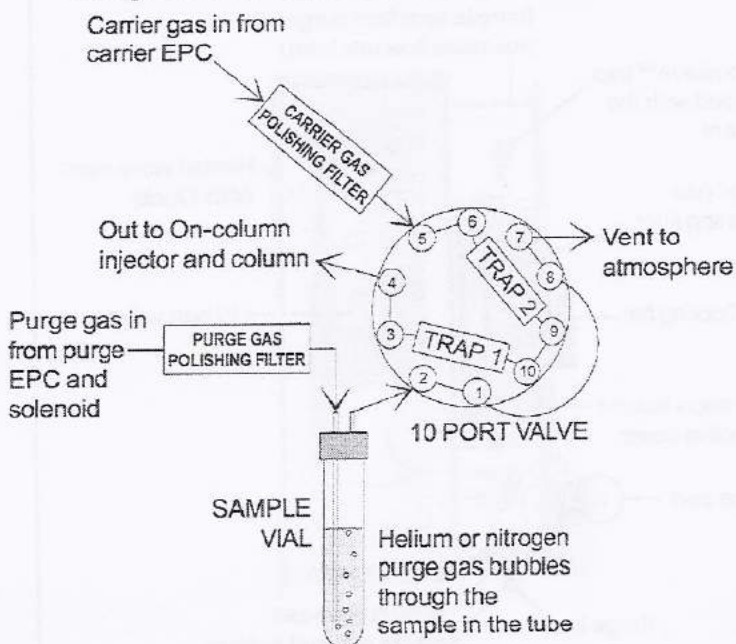

The SRI Purge & Trap uses a 10 port gas sampling valve and dual adsorbent traps. Each trap has independent adsorption and desorption setpoints to optimize the analyte trapping and releasing from each adsorbent.

When the valve is in the LOAD position, the sample-laden purge gas from the test tube or VOA vial is directed through the two traps, then out to vent, loading the traps with sample at the adsorption temperature (30-40°C). In this position, the carrier gas merely enters and exits the valve.

After a period of time sufficient for the traps to reach desorption temperature (200°C), the valve is actuated to the INJECT position. In the INJECT position, the carrier gas flows through the traps in the direction opposite to the sample-laden purge gas flow with which the traps were loaded. The carrier gas backflushes desorbed analytes into the column, while the purge gas flows out to vent.

The valve remains the INJECT position for the optional bake cycle, during which the respective desorption temperatures of both traps are raised an additional 50°C, and the purge gas polishing filter is reconditioned. A relatively high flow of purge gas sweeps through the hot polishing filter, which heats whenever TRAP 1 heats. This purge gas flow sweeps contaminants from the polishing filter and out to vent.

The valve is then actuated back into the LOAD position, TRAP 1 and the polishing filter heat are turned OFF, followed by TRAP 2, then the purge gas (see the Event Table on the *General Operating Procedures* page.)

Trap heating, valve rotation, and purge gas control are automated through the PeakSimple data system.

## Sample Preparation

Sample preparation depends on the sample type, concentration, amount, etc. The third edition of SW-846 from the EPA is accessible on the Internet. Go to <http://www.epa.gov/epaoswer/hazwaste/test/main.htm> and click on the **5000 Series** link to download Methods 5030 and 5035.

### Method 5030

Method 5030 style purge and trap is for the analysis of VOCs in aqueous samples. This purge and trap technique is limited to analytes that purge efficiently from water. 10mL of the sample is placed in a clean test tube. The test tube headspace will contain ambient air, so if your laboratory or work area is not free of solvent fumes, they will show up in your chromatogram.

For aqueous samples:

1. Insert a 10mL aliquot of the aqueous sample into a clean test tube.
2. Plug the test tube opening with your thumb and shake it until the contents are evenly dispersed.
3. Quickly slide the test tube over the purge gas tubing and into the purge head, and tighten it in place with the knurled retaining nut.
4. Immediately begin the analysis by pressing the RUN button on the front of the GC or by pressing the spacebar on your computer keyboard.

For medium concentration soil samples, do a quick methanol extraction:

1. Place 10g of sample into a clean glass container. Add 20mL of methanol and shake it for 1-3 minutes.
2. Allow the soil to settle, then pull 100 $\mu$ L of the liquid solution into a glass syringe and inject it into the test tube containing 10mL of organic free reagent water.
3. Plug the test tube opening with your thumb and shake it until the contents are evenly dispersed.
4. Begin the analysis. You may need to dilute the sample more or less, depending on the concentration.

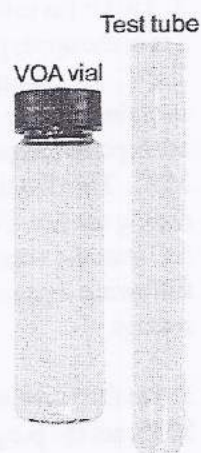

Always use clean sample containers

### Method 5035

Method 5035 style purge and trap is for the analysis of VOCs that are purgeable from soil at 40°C. This method does not allow the VOC's to escape the VOA vial until it is punctured by the 5035 purge head needles. Approximately 5g of soil, weighed in the field at the time of collection, is sealed in a pre-weighed, septum-sealed, screw-top VOA vial containing a preservative solution. There is no need to insert a magnetic stirring bar since the SRI purge and trap mechanically agitates the VOA vial during the analysis. Organic-free reagent water, surrogates, and internal standards (if applicable) are added through the syringe port immediately before beginning the analysis.

1. Insert the VOA vial containing 5g of soil and 5mL of reagent water into the Method 5035 purge head.
2. Using the syringe port, inject 5mL of organic free reagent water, internal standards, and surrogate compounds into the VOA vial.
3. Begin the analysis by pressing the RUN button or the computer keyboard spacebar.

# INJECTORS

## Purge & Trap

### General Operating Procedures

The following are generalized operating guidelines for the SRI Purge & Trap system.

1. The purge gas flow is controlled with an Electronic Pressure Controller (EPC). Set the purge flow (measurable at the trap vent at the rear of the purge and trap system). 40mL/min is a typical purge flow. The pressure required for 40mL/min through a single Tenax trap is printed on the right panel of the GC. If you install the optional Carbosieve trap or another adsorbent trap in the TRAP 2 position, you will need to raise the pressure to maintain the flow. **NEVER use hydrogen as a purge gas.** SRI recommends helium purge gas.

2. TRAP 1 is in the lower position in the Purge & Trap, and TRAP 2 is in the upper position. The trap temperatures are factory set at 200°C for desorption and may be adjusted using the trimpot setpoints on the top edge of the GC's front control panel. For adsorption temperatures, trap 1 is set at 30°C and trap 2 is set at 35°C. Trap heating will be controlled by the timed Event Table during the run. **Note:** the actual trap temperatures typically run 5°C over the setpoint. See the information and instructions on the following 2 pages for adjusting the trap adsorption temperature settings.

EVENT TIME	EVENT	EVENT FUNCTION
0.000	ZERO	Zero signal
0.100	E "ON"	Purge "ON"
0.200	(D "ON")	Shaker "ON"
5.000	(D "OFF")	Shaker "OFF"
5.100	E "OFF"	Purge "OFF"
6.000	C "ON"	Trap 2 (head) "ON"
6.050	F "ON"	Trap 1 (head) "ON"
8.000	G "ON"	Valve in "INJECT"
12.000	E "ON"	Purge "ON"
12.900	B "ON"	Trap set "ON" (+50°C)
13.000	G "OFF"	Valve in "LOAD"
14.900	F "OFF"	Trap 1 "OFF"
15.100	C "OFF"	Trap 2 "OFF"
15.300	E "OFF"	Purge "OFF"
15.500	B "OFF"	Trap set "OFF" (+0)

3. Set the valve oven temperature to 100°C or higher to avoid water condensation. If you're using Method 5035, set the purge head heater body temperature to 40°C. It is factory set to 40°C but is user adjustable.

4. Load or create an event table that is appropriate to the sample to be analyzed, or that is designed for compliance with a particular EPA Method. The valve oven in your Purge & Trap system is labeled with a typical Purge & Trap event table for a single Tenax trap. The event table shown above is an example for both methods; the only difference is that Method 5030 does not use Relay D (the sample vial shaker).

5. Load or create an appropriate temperature program for the column oven. **Epap&t.tem** is a typical Purge & Trap temperature program file provided with the PeakSimple software. As a basic rule for good separation, the column oven should be kept at 40°C for 10-12 minutes: the first 8 minutes of the run plus 2-4 more minutes after the valve actuates to the INJECT position.

6. Activate and energize the detectors as necessary. For instance, if you had an Environmental GC system, you would turn on the PID lamp current, light the FID flame, and set the DELCD reactor temperature. Choose the detector gain settings according to the analysis. Consult the manual sections for your particular detector(s) operating procedures.

7. When the system is at temperature and displaying a stable signal, insert the sample test tube or VOA vial into the purge head and begin the analysis.

**General Operating Procedures Continued**  
**Using Two Traps**

The SRI dual trap design gives the Purge & Trap user many options to effectively trap and release analytes from a particular adsorbent. Due to its low affinity for water, Tenax™-GR is especially useful for the purging of VOCs from aqueous samples, making it a good general purpose trap for EPA style purge and trap techniques. The Carbosieve™ packed trap is very retentive. Because it tends to retain a large water peak and smear the other peaks, it should only be used when vinyl chloride is among the target analytes. This tendency to smear may be reduced by manipulating the desorption times for the two traps. If the Carbosieve™ trap (TRAP 2) is desorbed while the Tenax™-GR trap (TRAP 1) is still cold, the components will refocus on the Tenax™-GR. The Tenax™-GR trap is then heated to desorb the components in a more narrow band, which results in sharper peaks on the chromatogram.

**Tenax™-GR Properties**

Composite of Tenax TA and 30% graphite  
Low water affinity  
350°C temperature limit  
200nm average pore size  
60/80 mesh size

Available from Alltech  
2051 Waukegan Road  
Deerfield, IL 60015 USA  
908-788-5550  
www.alltechweb.com

**Carbosieve™ S111 Properties**

Carbon molecular sieve  
Moderate water affinity  
400°C temperature limit  
15-40 angstrom average pore size  
60/80 mesh size

Available from Supelco  
Supleco Park  
Bellefonte PA 16823  
800-247-6628  
www.sigma-aldrich.com

**Dual Trap Event Table (Epap&t2c.evt)**

EVENT TIME	EVENT	EVENT FUNCTION
0.000	ZERO	Zero signal
0.100	E "ON"	Purge "ON"
5.100	E "OFF"	Purge "OFF"
6.000	C "ON"	Trap 2 (Carbosieve) heat "ON"
7.000	G "ON"	Valve in "INJECT"
8.000	G "OFF"	Valve in "LOAD"
8.100	F "ON"	Trap 1 (Tenax-GR) heat "ON"
10.000	G "ON"	Valve in "INJECT"
12.000	E "ON"	Purge "ON"
13.000	G "OFF"	Valve in "LOAD"
13.100	B "ON"	Trap set "ON" (+50°C)
14.800	F "OFF"	Trap 1 "OFF"
15.000	E "OFF"	Purge "OFF"
15.100	C "OFF"	Trap 2 "OFF"
15.200	B "OFF"	Trap set "OFF"

Version 2.66 of the PeakSimple software includes **Epap&t1c.evt** for a single trap, and **Epap&t2c.evt** for two traps.



## INJECTORS

### Purge & Trap

#### General Operating Procedures continued

#### Adjusting Trap Adsorption Temperatures

During the purge and trap process, the purge gas carries significant amounts of water into the traps. The Tenax™ trap is unaffected, due to its low affinity for water. The Carbosieve™ packing tends to retain the water, resulting in a large water peak at desorption. Adsorption settings can be adjusted by the user to set the Carbosieve trap at a high enough temperature to avoid water retention. However, this temperature may be too hot to trap target analytes. Therefore, experiment to find the adsorption temperatures that work best for your analyses. Once pinpointed, they usually require no further adjustment.

1. Remove the 6 screws that secure the bottom panel to the rest of the GC chassis. Support the panel while you gently rock the GC onto its back, then lower the panel to your working surface to access the chassis interior.

2. Locate the Purge & Trap board; it is one of a group of similar-looking boards installed along the back and top walls of the GC interior. The Purge & Trap board has two trimpots right next to each other, and it is marked with an upside-down "P&T" on the lower outer corner.

GC Chassis Interior

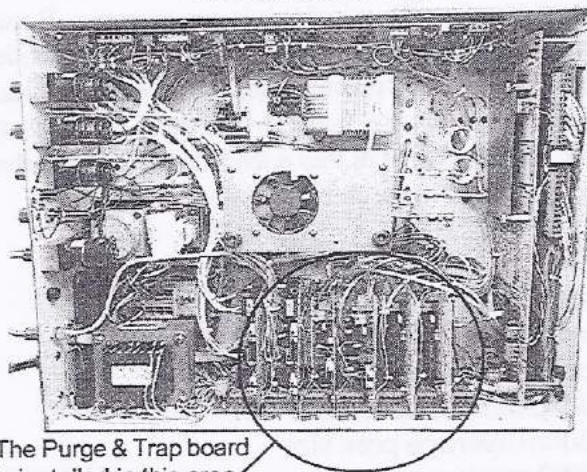

The Purge & Trap board is installed in this area inside the GC chassis

The Purge & Trap Board

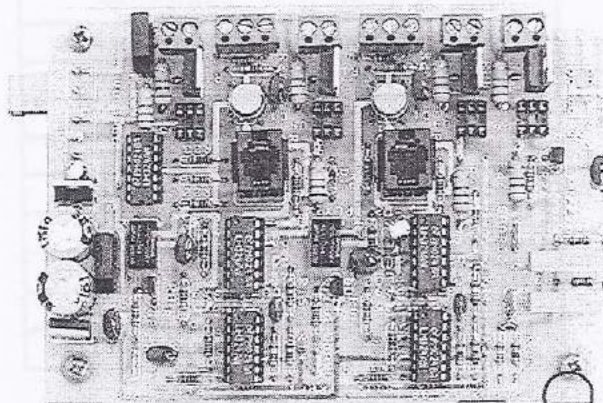

The Purge & Trap board is marked with "P&T" (upside down) on the lower right corner

—Trap 2 trimpot setpoint  
—Trap 1 trimpot setpoint

3. The two trap trimpot setpoints are on the outer edge of the board. The trimpot for Trap 1 is on the bottom, and the top trimpot is for Trap 2. Turn the trimpot while pressing the TOTAL button and observing the bright red LED display to set the trap adsorption temperature.

4. When you are finished adjusting both trap adsorption temperatures, place the bottom panel on the GC chassis. Support the panel while you gently rock the GC onto its base. Secure the base with its 6 screws.

## Switching / Replacing Traps

Three traps are included with your SRI Purge & Trap: a Tenax™-GR trap and a Carbosieve™ trap, both permanently packed, and a blank trap. The blank trap may be packed with an adsorbent of the user's choice or left blank, depending on the analytical situation. Follow the instructions below to access the traps for switching or replacement.

1. With the red protective GC cover raised, remove the Purge & Trap cover plate by loosening the four brass thumbscrews at its corners.
2. Carefully remove the two squares of white insulation from each valve oven duct to expose the fittings that secure the traps ends to the 1/16" O.D. tubing leading to the 10 port valve.
3. Gently slide the trap assembly out of the slots in the valve oven ducts (there is enough slack in the heater and thermocouple wires to pull either trap about 1 inch outside the duct).
4. Use two wrenches to loosen the 1/8" Swagelok type nuts that secure the traps ends to stainless steel 1/8"-1/16" reducing unions.
5. The trap heater is a clamshell design, consisting of two halves. To remove the heater from the trap, loosen but do not remove the two securing hex head screws. The two halves of the clamshell heater will open enough to let the trap drop out.
6. Attach the replacement trap to the reducing unions with the trap's two 1/8" nuts. Use stainless steel nuts and brass ferrules when replacing traps. **DO NOT** use graphite ferrules, as graphite has some adsorption properties and may interfere with your analysis.
7. Slip the trap into the clamshell heater and tighten the two hex head screws.
8. Gently push the trap ends back into the slots in the two interior duct walls, making sure that the black spacers are between the duct walls and the trap heater. **TO AVOID DAMAGE, ARRANGE THE TRAPS SO THAT ONE TRAP'S HEATER WIRES DO NOT LAY ACROSS THE OTHER TRAP'S HEATER.**
9. Repeat the process with the other trap if necessary. Replace the white duct insulation squares, then replace and secure the Purge & Trap cover plate.

### SRI Trap Assembly

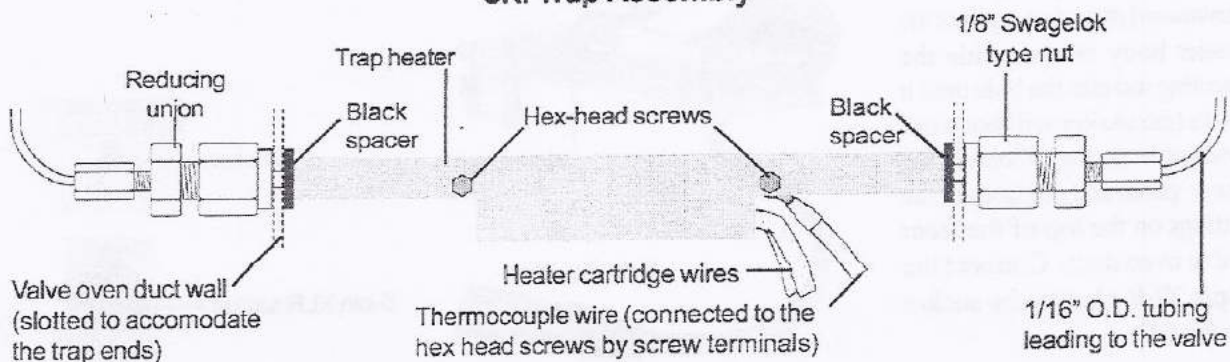

# INJECTORS

## Purge & Trap

### Method 5030/5035 Purge & Trap: Changing the Purge Heads

1. To change the purge heads, first disconnect the two purge gas lines at their fittings on the top of the front valve oven duct.

2. If you are removing the 5030 purge head, pull it out toward the front of the GC, and unplug the 5-pin XLR dummy plug.

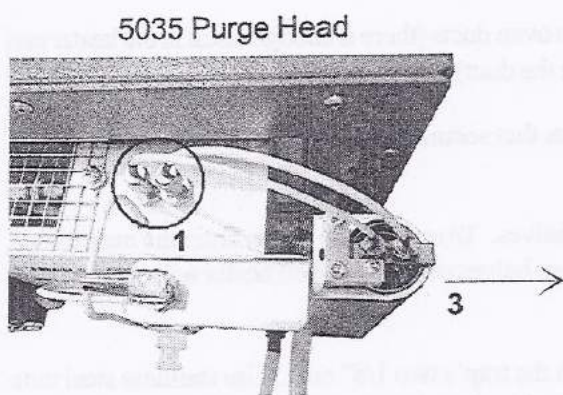
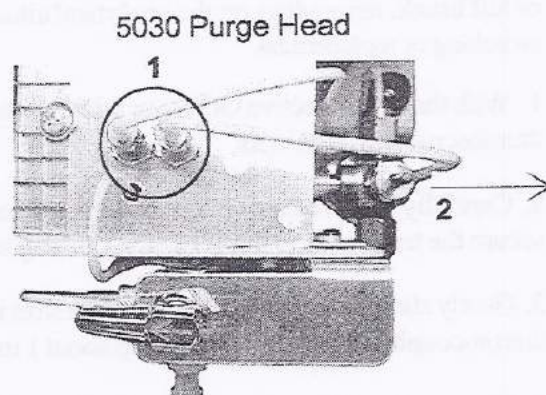

3. If you are removing the 5035 purge head, squeeze the protruding tail of the spring toward the heater body with your thumb as you pull the purge head out toward the front of the GC. Unplug the cord from the socket on the GC.

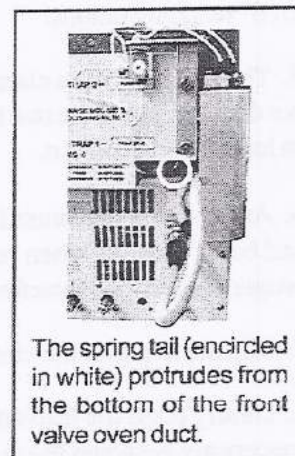

4. To install the 5030 purge head, line up the securing rod with the hole, and gently but firmly push it in until it locks into place. Connect the purge gas in and out lines to the fittings on the top of the front valve oven duct. Connect the dummy 5-pin XLR plug to the socket on the GC.

5. To install the 5035 purge head, hold the spring tail in a downward direction against the heater body as you slide the securing rod into the hole until it locks (the shaker will not work without the spring). Connect the purge gas in and out lines to the fittings on the top of the front valve oven duct. Connect the 5-pin XLR plug to the socket on the GC.

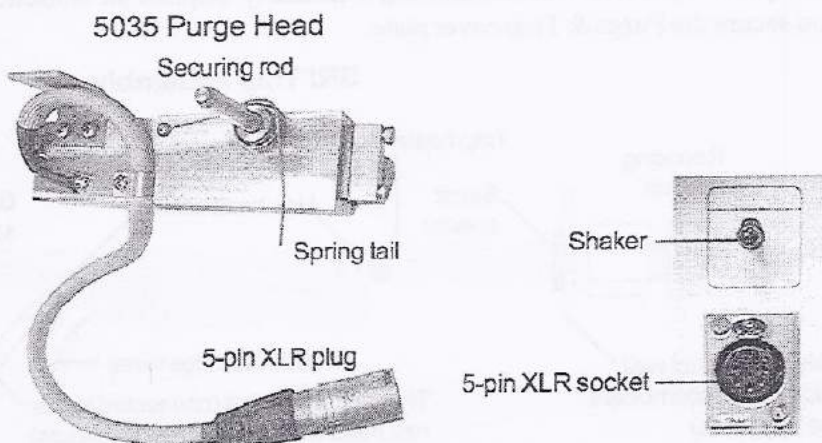

## Expected Performance

The following two sets of chromatograms are from an Environmental GC system equipped with a Method 5030 compliant Purge & Trap, a PID detector, and a FID/DELCD combination detector. First, a 10ppb BTEX Plus sample was analyzed using the 5030 event table on the **General Operating Procedures** page and the **Epap&t.tem** temperature file. Second, a water blank was run through the system under identical conditions to show the component carry-over level of the Purge & Trap system. Toluene is used as a representative of the carryover in the Purge & Trap system; if the carryover level of Toluene is below 0.5ppb, then it will not affect subsequent analyses. NOTE: The TCE ghost peaks in the water blank chromatograms are augmented or caused by our factory test laboratory contamination.

Sample: 1µL 100ppm BTEX Plus dissolved in 10mL of water to yield 10ppb BTEX Plus

**FID Results:**

Component	Retention	Area
Solvent	10.616	921.0990
Benzene	15.033	1019.9260
TCE	15.883	441.8700
Toluene	17.683	1195.3320
PCE	18.700	383.3770
Ethyl Benzene	20.016	1247.3420
Ortho Xylene	20.800	1258.9260
Bromoform	21.166	78.9360
<b>Total</b>		<b>6546.8080</b>

**PID Results:**

Component	Retention	Area
Benzene	15.016	311.1630
TCE	15.866	258.4360
Toluene	17.666	353.2160
PCE	18.683	233.4780
Ethyl Benzene	20.000	343.9640
Ortho Xylene	20.783	350.7040
Bromoform	21.133	32.3470
<b>Total</b>		<b>1883.3080</b>

**DELCD Results:**

Component	Retention	Area
TCE	15.883	192.1020
PCE	18.683	209.2260
Bromoform	21.150	126.2820
<b>Total</b>		<b>527.6100</b>

Sample: clean water blank (NOTE: the chromatograms are magnified for carryover visibility)

**FID Results:**

Component	Retention	Area
TCE	15.883	441.8700
Toluene	17.566	17.4000
Ethyl Benzene	20.016	1247.3420
Ortho Xylene	20.800	1258.9260
<b>Total</b>		<b>6546.8080</b>

**PID Results:**

Component	Retention	Area
TCE	15.866	258.4360
Toluene	17.533	4.340
Ortho Xylene	20.783	350.7040
<b>Total</b>		<b>609.1300</b>

**DELCD Results:**

Component	Retention	Area
TCE	15.750	46.0340

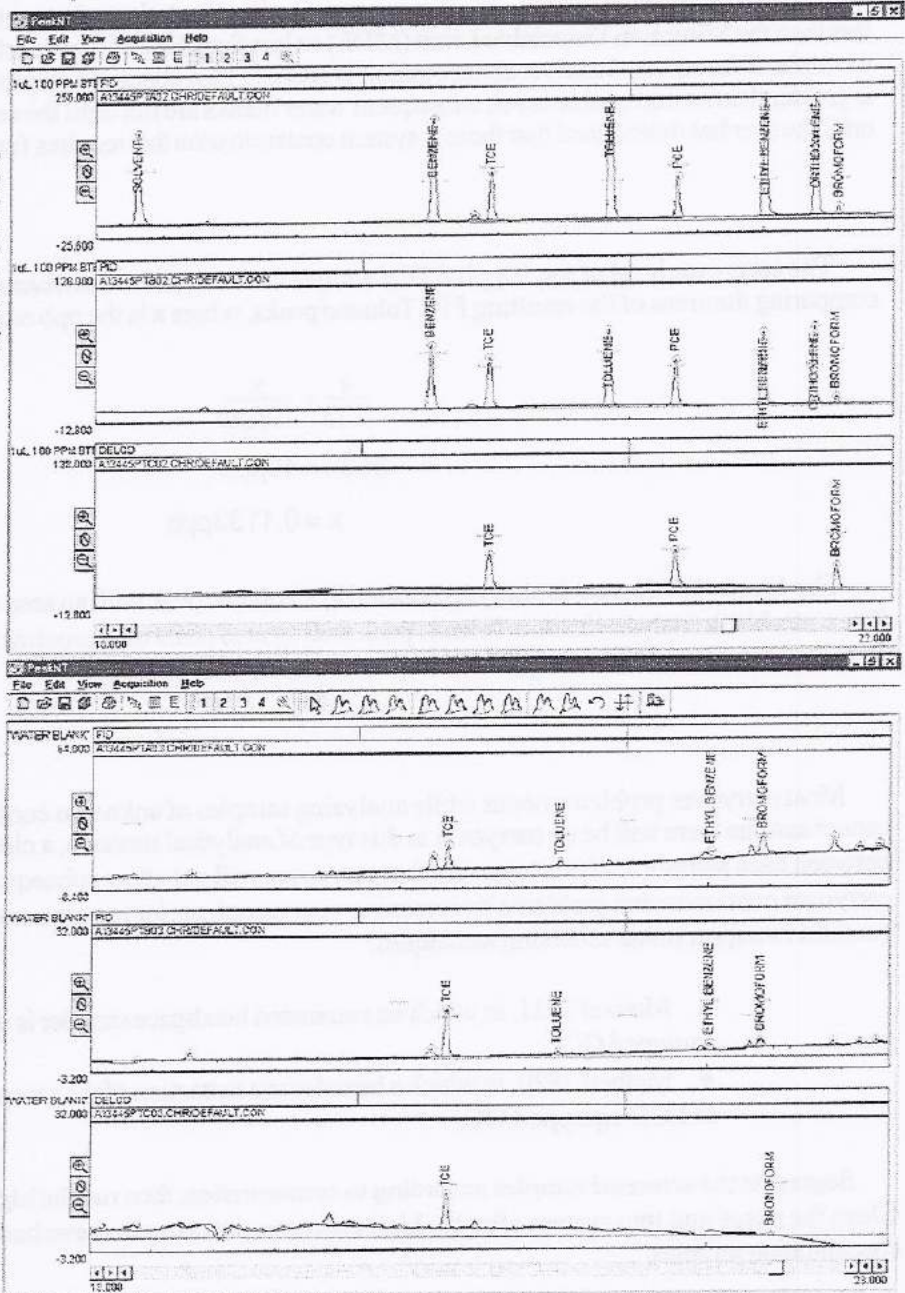

## INJECTORS

### Purge & Trap

---

### *Troubleshooting and Maintenance*

#### **Carryover**

Carryover is a slight contamination of the purge and trap system by analytes (especially high boiling components), and is a normal condition of operation. All purge and trap systems exhibit some carryover. An organic free reagent water blank is analyzed after sample runs to determine the carryover level, as shown on the *Expected performance* page. Most regulatory Quality Control requirements allow carryover that is either less than the Minimum Detectable Limit (MDL) or less than 10% of the reported analyte concentration. For example, if the reported analyte concentration is 100ppb, then 10ppb is acceptable carryover. If the carryover is greater than an acceptable level, subsequent water blanks are run until the carryover is sufficiently low, or until the user has determined that there is system contamination that requires further cleaning.

The carryover level of the 10ppb BTEX sample on the *Expected performance* page was determined by comparing the areas of the resulting PID Toluene peaks, where  $x$  is the ppb concentration of the carryover:

$$\frac{4}{353} = \frac{x}{10\text{ppb}}$$
$$353x = 40\text{ppb}$$
$$x = 0.1133\text{ppb}$$

The 10ppb BTEX sample analysis resulted in a Toluene peak with an area count of approximately 353. The water blank analysis shows a Toluene peak with an area count of approximately 4. Since the carryover of Toluene is less than 10% or 0.5ppb, subsequent analyses may be resumed.

Most carryover problems occur while analyzing samples of unknown concentration. Because the user cannot assume there will be no carryover in this type of analytical situation, a clean water blank should be run between each sample analysis to ensure that carryover will not affect subsequent sample analyses. Avoid carryover contamination problems by screening your samples prior to purge and trap GC analysis. SW-846 contains two appropriate screening techniques:

- ◆ Method 5021, in which an automated headspace sampler is used with a PID and DELCD equipped GC
- ◆ Method 3820, in which a hexadecane extraction of the sample is analyzed by a FID and/or ECD equipped GC.

Segregate the screened samples according to concentration, then run the highly concentrated ones first. Clean the purge and trap system after the high concentration samples have been run, then analyze the low concentration samples.

Chapter: PURGE AND TRAP CONCENTRATOR

Topic: HARDWARE ORIENTATION

Cooling fan for traps maintains selected adsorbent temperature and rapidly lowers trap temperature from desorbent temperature ( typically 200 C )

Purge and Trap Sample Concentrator Option is mounted in the special ducted heated valve oven located on the left side of the 8610C Gas Chromatograph. The Purge and Trap option is not available on the Model 310 GC.

Purge vessel uses disposable 16mm test tubes and rugged needle sparging tube. Sparge head allows gas standards to be spiked in through built-in septum port.

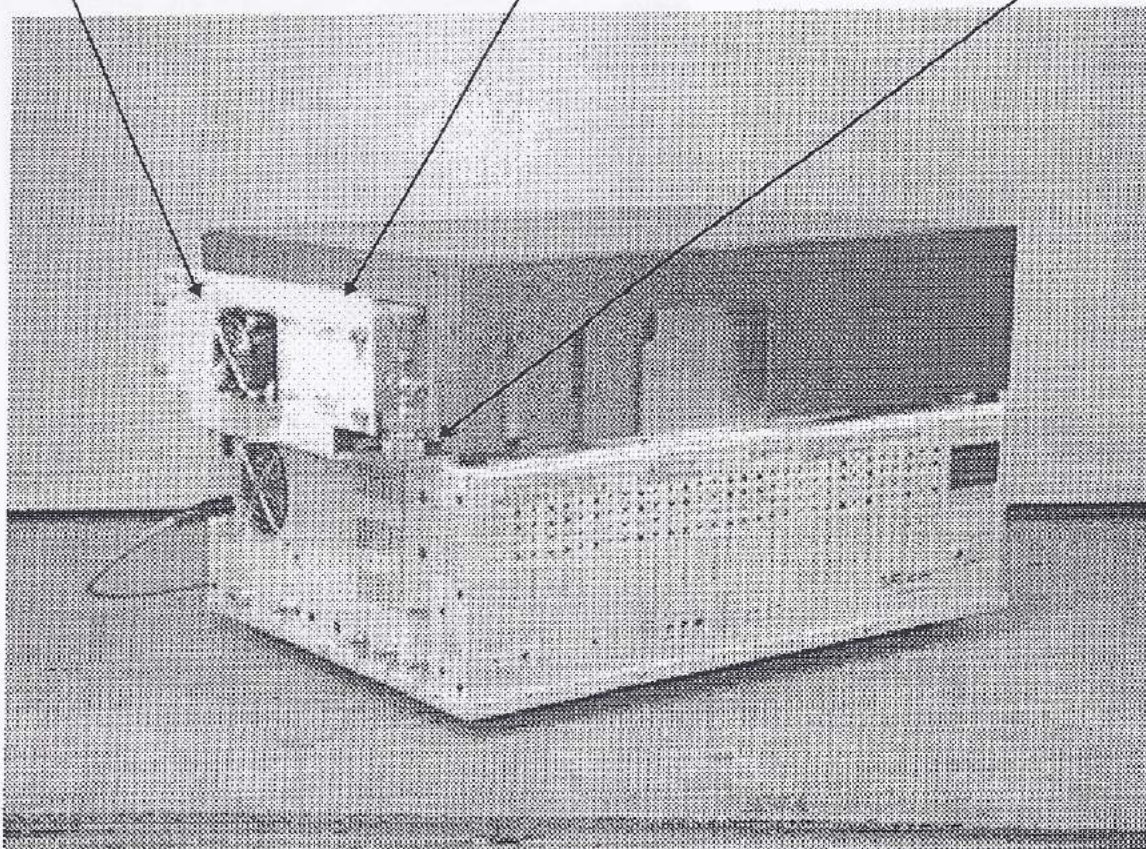

The SRI Purge and Trap concentrator allows low levels of organic compounds in water to be automatically extracted from the water matrix and collected on one or two series mounted adsorbent traps. The purge and trap technique is applicable to a broad range of molecules from about C3 to C12. Molecules heavier than C12 do not purge well from water nor do polar molecules which resist purging due to their solubility. The SRI Purge and Trap is unique because of the dual trap design which allows two different adsorbent trapping materials to be used, and each material can be adsorbed and desorbed at individual temperatures and different times. This flexibility allows for tighter desorbent bandwidths, and greater water rejection than other Purge and trap designs which have only a single mixed adsorbent bed trap. Additionally, the disposable test tubes which hold the water sample are inexpensive ( 5 cents each U.S ) so they can be thrown away in the event of contamination. A 10 position autosampler can be easily added to the Purge and trap for un-attended operation.

# Chapter: PURGE AND TRAP CONCENTRATOR

## Topic: HARDWARE ORIENTATION

Column oven

The Purge and Trap option is mounted on the GC chassis in a special ducted heated valve oven just to the left of the column oven

To change traps this cover plate must be removed by loosening the four brass thumbscrews located at the corners.

Traps are located between ducts so that the ends of the traps are enclosed within the heated duct area while the body of the traps are suspended in the trap heaters between the ducts. A protective grill keeps fingers and tools out of the trap heat zone while allowing hot air to escape.

A vent tube is located at the back of the P&T valve oven. The sparge gas exits from this vent tube after passing through the traps.

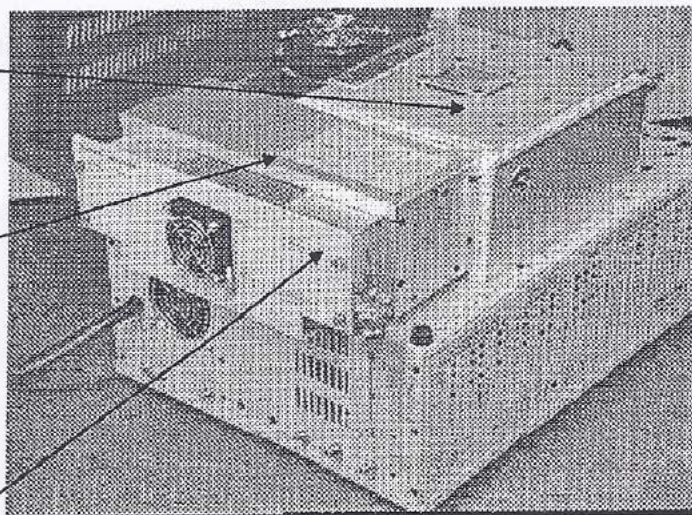

10 port electrically operated Valco valve mounted in the heated valve oven is the heart of the purge and trap hardware. The valve oven is typically set to 150 degrees C so water will not condense.

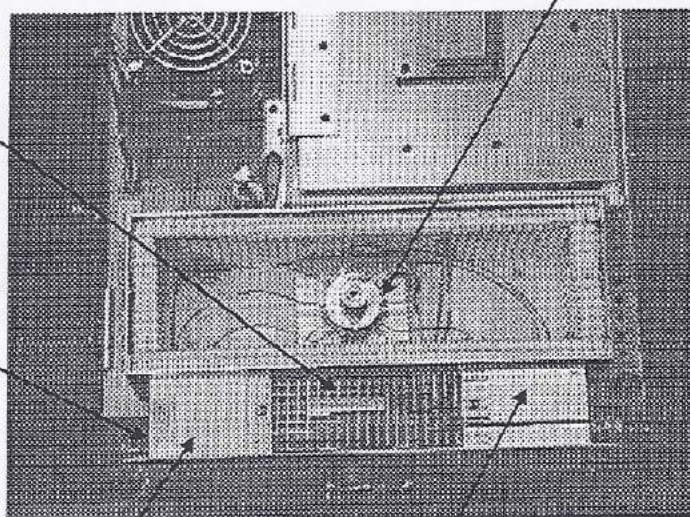

Ducts enclose ends of traps within heated valve oven to prevent cold spots.

Chapter: PURGE AND TRAP CONCENTRATOR

Topic: HARDWARE ORIENTATION

Remove the protective wire grill from the top of the valve oven for better access to the traps

Remove the two squares of white insulation from each duct to expose the fittings which secure the trap ends to the 1/16th inch O.D. tubing leading to the Valco valve.

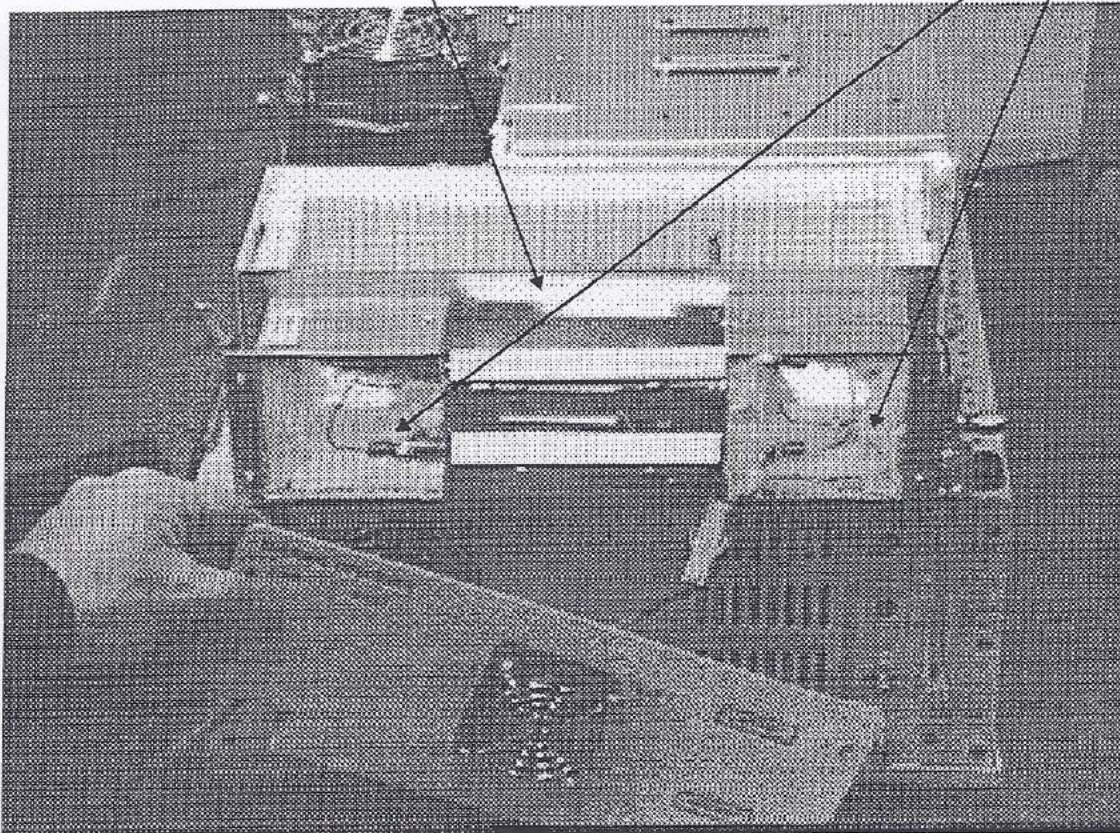

To access the traps for maintenance or replacement:

- 1) Remove the left side plate from the purge and trap valve oven by loosening the 4 brass thumbscrews at the corners.
- 2) Remove the protective grill from the top of the valve oven by loosening the two screws.
- 3) Carefully remove the two squares of white insulation from the ducts at the ends of the traps.



Chapter: PURGE AND TRAP CONCENTRATOR

Topic: HARDWARE ORIENTATION

1/8th to 1/16th reducing fitting at end of trap

Clamshell type trap heater halves can be separated by loosening two hex head type screws.

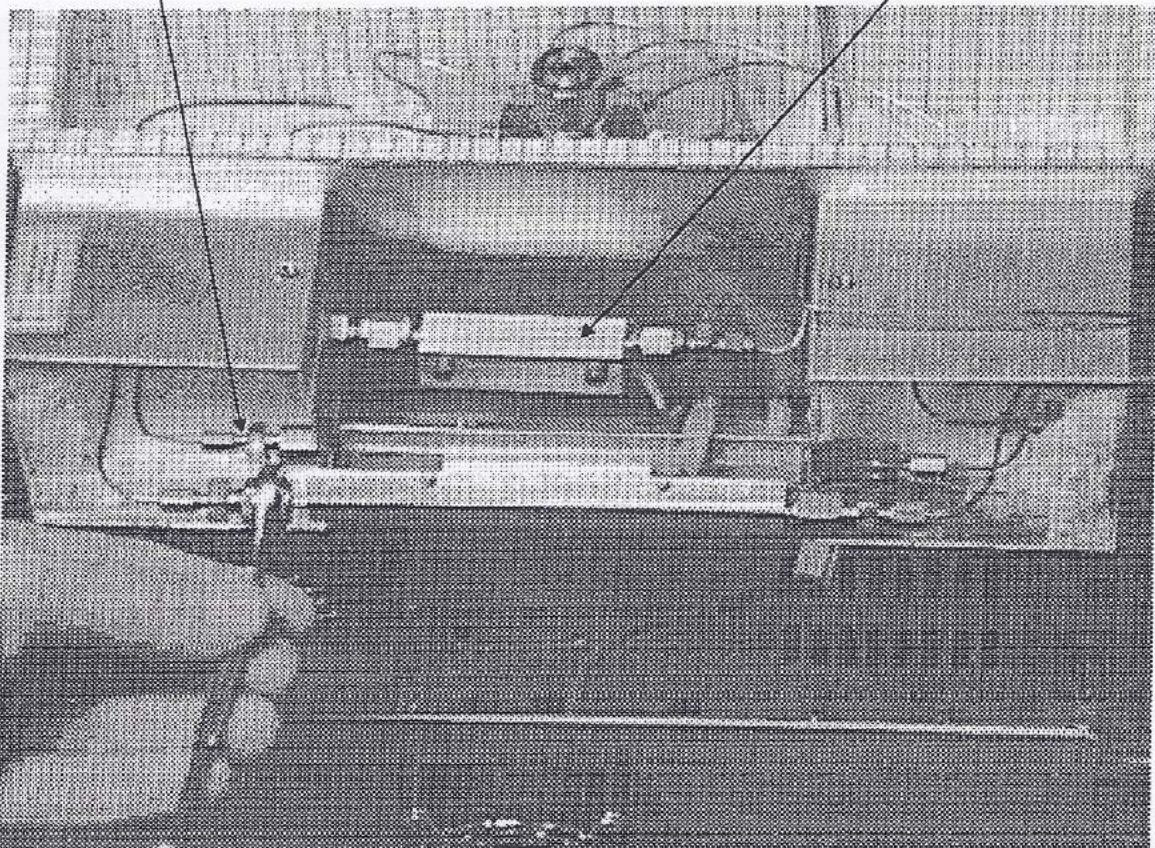

There is enough slack in the heater/thermo-couple wires to pull the trap about 1 inch beyond the duct . To remove the trap :

- 1) Loosen the 1/8th inch swagelok type nuts which secure the trap ends to stainless steel 1/8 to 1/16th reducing unions using two wrenches.
- 2) The trap heater is a clamshell design which will separate when the two hex head screws holding the heater together are loosened. With the trap heater apart the trap itself can be removed.

Use this troubleshooting flowchart if you are experiencing difficulty with contamination when performing purge and trap analyses.

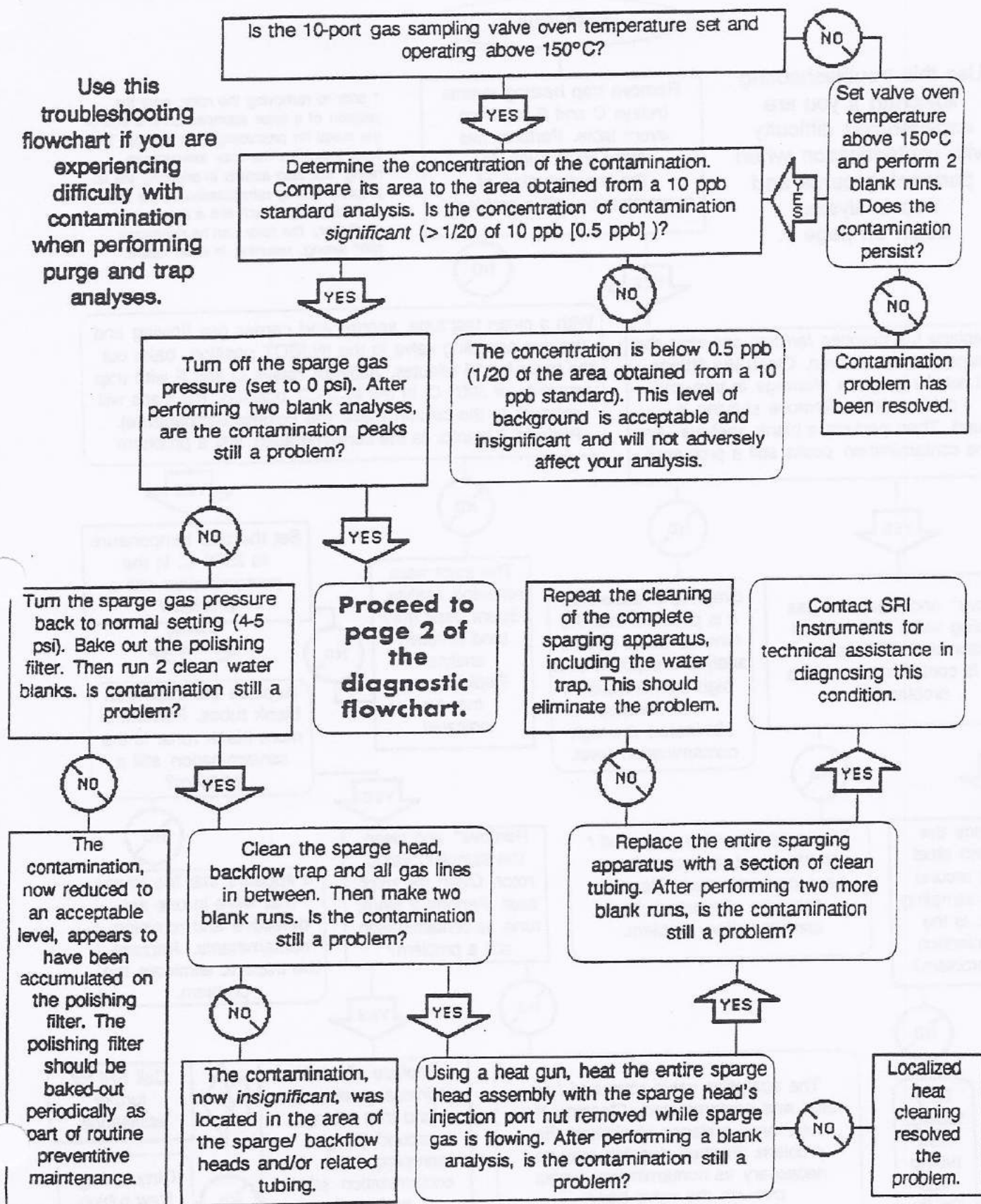

Use this troubleshooting flowchart if you are experiencing difficulty with contamination when performing purge and trap analyses. Begin on page 1.

From page 1

Remove trap heating events (relays C and F on) from event table. Perform two more blank runs. Is the concentration of contamination still a problem?

\* prior to removing the rotor, note the position of a letter stamped on one end of the metal fin protruding from the top. This letter indicates the rotor temperature rating, but also assists in orienting the fin properly during reinstallation of the rotor after cleaning. Much like a automotive distributor, the rotor can be reinserted 180° wrong, resulting in valve failure.

YES NO

Replace the graphite ferrules securing the traps and the column. Clean the fittings. Look for graphite shavings in trap and column ends. Remove shaving if found. Then perform a blank analysis. Are the contamination peaks still a problem?

With a clean test tube, sparge and carrier gas flowing and the gas sampling valve in the INJECT position, bake out the traps for 15 minutes. Activate relays C and F with trap setpoints of 300° C. In the INJECT position, the traps will exhaust to the column (raise the column temperature). Perform 2 blanks. Is the contamination still a problem?

YES NO

Remove\* and clean the gas sampling valve rotor. Clean the rotor seat. Reinstall the rotor. Is contamination still a problem?

Graphite is adsorbent. It is possible that the ferrules could adsorb analyte if exposed to a high concentration. New ferrules eliminated the high contamination level.

The traps were retaining analyte. Spent traps may tend to retain analyte. Replacement may be indicated.

Set the trap temperature to 250° C. Is the contamination still a problem?

NO YES  
Replace the traps with blank tubes. Perform 2 more blank runs. Is the contamination still a problem?

YES NO  
Replace the stainless steel tubing around the gas sampling valve. Is the contamination still a problem?

The sampling valve rotor and / or rotor seat appear to have been contaminated. Cleaning the area eliminated the contamination problem.

Remove\* and clean the sampling valve rotor. Clean the rotor seat. Perform 2 blank runs. Is contamination still a problem?

NO  
It appears that the traps that were in use are defective and retaining contaminants. Replace the traps to eliminate the problem.

YES NO  
Call SRI for tech. support Dirty tubing. New tubing was the fix.

NO  
The sampling valve rotor and / or seat was contaminated. Cleaning the rotor area surfaces eliminated the problem. Further cleaning may be necessary as contamination works through the valve body.

YES  
Replace all 1/16" stainless steel purge and trap tubing around the gas sampling valve. Is contamination still a problem?

NO YES  
Call SRI for further assistance. Dirty tubing. New tubing was the fix.

# Effectiveness of Purge-and-Trap for Measurement of Volatile Organic Compounds in Aged Soils

Minoo D. F. Askari,<sup>†</sup> Michael P. Maskarinec,<sup>‡</sup> Stacy M. Smith,<sup>‡</sup> Paul M. Beam,<sup>§</sup> and Curtis C. Travis<sup>\*1</sup>

University of Tennessee, Knoxville, Tennessee 37996, EM-451, 1000 Independence Avenue, U.S. Department of Energy, Washington, D.C. 20585, and Chemical and Analytical Sciences and Health Sciences Research Divisions, Oak Ridge National Laboratories, Oak Ridge, Tennessee 37830

The U.S. EPA-recommended method for measurement of trace levels of volatile organic compounds (VOCs) in soil, purge-and-trap, measures the readily desorbable organic contaminants from soil pore spaces and external soil surfaces. It does not, however, measure contamination that has diffused into internal micropores of soil matrix. Thus, the purge-and-trap method measures only a small fraction of total soil contaminants, especially in long-contaminated soils, where ~90–99% of contamination may be in the interior of the soil matrix. We compared three methods for determination of VOCs in aged field samples: purge-and-trap, methanol immersion, and hot solvent extraction. Hot solvent extraction proved to be much more effective than the U.S. EPA-approved purge-and-trap technique. For three long-contaminated soils containing such VOCs as trichloroethene, benzene, toluene, chloroform, methylene chloride, and *cis*-1,1-dichloroethylene, recovery from purge-and-trap ranged between 1.5 and 41.3% that of hot solvent extraction. Our data show that purge-and-trap may not be the best methodology for measuring soil VOCs concentrations, particularly in aged soils. It is clear from this and previous studies that the best overall choice for soil VOCs measurements is hot solvent extraction. These results also indicate the inefficiency of purge-and-trap as a method for evaluating vapor extraction remediation technology. Our results suggest that the EPA should review the use of the purge-and-trap method for measuring VOCs concentrations in soils.

A critical requirement in the cleanup of contaminated soil sites is an accurate determination of the nature and extent of soil contamination. The primary U.S. EPA-recommended method (EPA/SW-846-5030A and 8260A) for measurement of volatile organic compounds (VOCs) in soils is purge-and-trap,<sup>1,24,25</sup> followed by gas chromatography/mass spectroscopy. Under this protocol, organic-free water containing internal standards and surrogates is mixed with a soil sample and heated to 40 °C. An inert gas is bubbled through the solution at ambient temperature, and the vapor is passed through a sorbent column, where the volatile components are adsorbed. After purging is completed, the sorbent column is heated and backflushed with inert gas to desorb

the components onto a gas chromatographic column.<sup>1</sup> Use of purge-and-trap to measure VOCs in soil is based on the assumption that soil VOCs rapidly equilibrate with soil water. Recent studies,<sup>2–5</sup> however, strongly question this assumption and indicate that soil desorption is a biphasic process with an initial rapid surface desorption followed by a much slower, diffusion-limited, desorptive phase from the interior of the soil matrix.<sup>2–4,6–11</sup>

The biphasic nature of desorption casts doubt on the widely used, EPA-recommended purge-and-trap method. When soil has been in contact with VOCs for a long time period (aged soils), VOCs diffuse into soil micropores, where they are unavailable for purge-and-trap measurement. Except for a single study<sup>8</sup> involving 1,2-dibromoethane (EDB), the impact of soil aging on the effectiveness of VOCs measurement techniques is largely unexplored. The present study focuses on the effectiveness of three commonly used techniques for measuring VOCs concentrations in aged soils: purge-and-trap, methanol immersion, and hot methanol extraction. Since vapor extraction is a currently popular technique for removal of VOCs from soils, we subjected one soil sample to air stripping to evaluate the effect of vapor extraction on the extraction efficiency of purge-and-trap measurements.

## EXPERIMENTAL PROCEDURE

**Soils.** Soil samples were obtained from three geographically distributed sites with a 10–20-year history of VOCs contamination. The Kentucky soil had high clay content, with 100 ppb of trichloroethylene. The Louisiana soil was a silty loam, with 3000 ppb of *cis*-1,1-dichloroethylene and 6000 ppb of trichloroethylene. The Florida soil was silty, fine to very fine sand, containing methylene chloride at 240 ppb, benzene at 2 ppb, toluene at 190 ppb, and chloroform at 2 ppb.

**Sample Collection.** Soil samples were extracted with a hollow-stem auger and split-spoon sampler. Undisturbed soil

<sup>†</sup> University of Tennessee.

<sup>‡</sup> Chemical and Analytical Sciences Division, ORNL.

<sup>§</sup> U.S. Department of Energy.

<sup>\*</sup> Health Sciences Research Division, ORNL.

(1) Environmental Protection Agency. *Code of Federal Regulations*, Part 261; Title 40; U.S. Government Printing Office: Washington, DC, 1994; Chapter 1, App. III, p 67 (July 1, 1994).

(2) Steinberg, S. M.; Pignatello, J. J.; Sawhney, B. L. *Environ. Sci. Technol.* 1987, 21, 1201–1208.

(3) Pavlostathis, S. G.; Mathavan, G. N. *Environ. Sci. Technol.* 1992, 26, 532–538.

(4) Kan, A. T.; Fu, G. *Environ. Sci. Technol.* 1994, 28, 859–867.

(5) Fares, A.; Kindet, B. T.; Lapuma, P.; Perram, G. P. *Environ. Sci. Technol.* 1995, 29, 1564–1568.

(6) Pignatello, J. J. *Environ. Toxicol. Chem.* 1990, 9, 1107–1115.

(7) Pignatello, J. J.; Frink, C. R.; Marin, P. A.; Dorste, E. X. *J. Contamin. Hydrol.* 1990, 5, 195–214.

(8) Sawhney, B. L.; Pignatello, J. J.; Steinberg, S. M. *J. Environ. Qual.* 1988, 17, 149–152.

(9) Witkowski, P. J.; Gaff, P. R.; Ferrara, R. A. *J. Contamin. Hydrol.* 1988, 2, 249–269.

(10) Pavlostathis, S. G.; Jaglal, K. *Environ. Sci. Technol.* 1991, 25, 274–279.

(11) Travis, C. C.; MacInnis, J. M. *Environ. Sci. Technol.* 1992, 26, 1885–1887.

**Table 1. Comparison of Three Methods for measuring VOCs in Soils**

soil type, component	compounds	purge-and-trap <sup>a</sup> (mg/kg)	methanol immersion <sup>a</sup> (mg/kg)	hot methanol extraction <sup>a</sup> (mg/kg)
Kentucky (clay)	trichloroethylene	100 ± 57	140 ± 15	240 ± 31 <sup>c</sup>
	<i>cis</i> -1,1-dichloroethylene	3070 ± 351	26 000 ± 4359 <sup>b</sup>	41 700 ± 2082 <sup>b</sup>
Louisiana (silty loam)	trichloroethylene	5900 ± 1210	85 000 ± 13 115 <sup>b</sup>	121 700 ± 11 719 <sup>b</sup>
	methylene chloride	240 ± 63	530 ± 31 <sup>b</sup>	630 ± 58 <sup>b</sup>
Florida (silty, fine to very fine sand)	benzene	2 ± 1	110 ± 5 <sup>b</sup>	150 ± 25 <sup>b</sup>
	toluene	190 ± 41	240 ± 11 <sup>c</sup>	270 ± 37 <sup>b</sup>
	chloroform	2 ± 0	110 ± 5 <sup>b</sup>	130 ± 25 <sup>b</sup>

<sup>a</sup> Average of three soil sample measurements. <sup>b</sup> Significantly higher mean than purge-and-trap at 95% level of confidence. <sup>c</sup> Significantly higher mean than purge-and-trap at 90% level of confidence.

**Table 2. Comparison of Extraction Methods for Louisiana Soil after 1 Week of Air Stripping**

compound	purge-and-trap <sup>a</sup> (mg/kg)	methanol immersion <sup>a</sup> (mg/kg)	hot methanol extraction <sup>a</sup> (mg/kg)
methylene chloride	94 ± 50	150 ± 43	160 ± 110
<i>cis</i> -1,1-dichloroethylene	86 ± 39	390 ± 122 <sup>b</sup>	2110 ± 1688 <sup>c</sup>
trichloroethylene	310 ± 60	5400 ± 916 <sup>b</sup>	5500 ± 1081 <sup>b</sup>

<sup>a</sup> Average of three soil sample measurements. <sup>b</sup> Significantly higher mean than purge-and-trap at 95% level of confidence. <sup>c</sup> Significantly higher mean than purge-and-trap at 90% level of confidence.

cores were sealed in glass jars with minimum headspace and stored at 4 °C on arrival. At the start of each experiment, the sample core was plugged and subdivided to obtain three 5-g subsamples. Subsamples were extruded directly into VOA vials (Dynatech, Baton Rouge, LA) and mixed with 5 mL of water containing internal standards and surrogates before capping.

**Measurements of VOCs.** Contaminants were extracted from soil samples by methods of purge-and-trap, methanol immersion, and hot methanol extraction. Contaminant concentrations were expressed as micrograms per kilogram of soil.

**Purge-and-Trap.** Sample aliquots were purged using a Dynatech PTA-30 autosampler and a Tekmar (Cincinnati, OH) LSC-2 purge-and-trap device. Soil samples of 2 g each were purged at 40 °C. The trap was desorbed, and measurement was performed with a Hewlett-Packard Model 5890/5971 GC/MS, using an EPA method 8260.<sup>12,13</sup> All quality assurance measures given in the method were followed.

**Methanol Immersion.** Five milliliters of purge-and-trap grade methanol was added to sample aliquots. The vial was capped as previously described and vigorously shaken for 30 s to facilitate wetting of the soil surface. A 50- $\mu$ L aliquot of the methanol was then removed and added to 5 mL of water containing internal standards and surrogates. The water was then subjected to purge-and-trap and analyzed for the concentration of chemicals by GC.

**Hot Methanol Extraction.** Hot methanol extraction was performed in the same manner as methanol immersion except that, prior to withdrawal of the aliquot of methanol, the VOA vial was placed in a 40 °C ultrasonic water bath for 30 min. The methanol was drawn and analyzed as described above.

**Extraction Following Air Stripping.** The Louisiana sample was mixed in a 7:3 ratio with calcium oxide to prevent solidification during air stripping. The sample was then placed in a Buchner

funnel with a vacuum running from the bottom of the funnel through a flask. Ambient air was passed through the sample using a vacuum of 450–675 mmHg for 1 week. Occasional mixing of the soil was performed throughout this time. The soil sample was divided into three subsamples, and each subsample was then subjected to one of the three methods as previously described.

All of the above extractions was performed as written in EPA/SW-846 methodology. Internal standards were added, and surrogate recovery was within the limits of the method for all extractions. All quality assurance procedures were applied.

## RESULTS

Measurement results from the three different sites—Kentucky, Louisiana, and Florida—are presented in Table 1. Trichloroethylene was the only contaminant detected in the Kentucky soil (Table 1), with a purge-and-trap recovery only 42% as compared to hot methanol extraction. Both *cis*-1,1-dichloroethylene and trichloroethene were detected in the Louisiana soil. Purge-and-trap recovery of these two contaminants was only 7.4 and 4.8%, respectively, when compared to hot methanol extraction method. Four compounds were identified in the Florida soil: methylene chloride, benzene, toluene, and chloroform, with purge-and-trap recovery 38.0, 1.5, 71.2, and 1.5%, respectively, in comparison to hot methanol extraction.

**Effect of Air Stripping.** Contaminant concentrations for air-stripped Louisiana soil are presented in Table 2. Purge-and-trap detected levels of methylene chloride, *cis*-1,1-dichloroethylene, and TCE at 58, 4.1, and 5.6%, respectively, that of hot methanol extraction. Comparison of these results with those in Table 1 for Louisiana soils indicates that air stripping does not appear to affect the distribution of contaminants between the accessible and inaccessible phases.

## DISCUSSION

Purge-and-trap is the EPA-recommended method (EPA/SW-846-5030A) for measurement of VOCs in soils. Under the

(12) Conder, J. R.; Young, C. L. *Physicochemical Measurement by Gas Chromatography*; John Wiley and Sons: New York, 1979.

(13) Laub, R. J.; Pecsok, R. L. *Physicochemical Applications of Gas Chromatography*; John Wiley and Sons: New York, 1978.

protocol, organic-free water is mixed with a soil sample and heated to 40 °C. An inert gas is bubbled through the water, and the concentration of chemicals in the gas is measured with a gas chromatograph. This method is effective only if VOCs in soils rapidly desorb from the soil surface into surrounding water. Laboratory control samples using sea sand in place of soils indicate that, for nonadsorptive solids, purge-and-trap recovery is acceptable. Recent studies<sup>2-4,8,14,15</sup> on the physical inaccessibility of contamination in soils suggest that this may not be the case, particularly in long-contaminated soils. It has been hypothesized that aging involves diffusion into soil micropores, partitioning into soil organic matter, strong surface adsorption, or a combination of these processes.<sup>2,14,16,17</sup> Previous studies<sup>6,18</sup> indicate that 20–90% of contamination may be located in the interior of the soil matrix and thus inaccessible for purge-and-trap measurement. The purpose of the present study was to compare the effectiveness of three commonly used techniques for measuring VOCs in soils: purge-and-trap, methanol immersion, and hot methanol extraction. We found that purge-and-trap consistently underestimated the concentration of VOCs in aged soils by factors ranging from 2 to ~100. This consistent underestimation of soil concentrations undermines the EPA's attempt to remediate contaminated soils to levels consistent with health-based cleanup standards.

The soil desorption process is known to involve two distinct phases: a rapid desorption from the soil surface occurring within 24 h and a much slower diffusion-limited desorption from the interior of the soil matrix occurring over a period of days to years.<sup>5,19</sup> This biphasic desorption pattern is most pronounced in aged soils, where a significant fraction of contamination is located in the interior of the soil matrix. For example, despite its high volatility and degradability, 1,2-dibromoethane (EDB), a soil fumigant, was found<sup>8</sup> in agricultural topsoil 19 years after its last known application. The persistence of EDB was attributed to desorption half-times of 2–3 decades at 25 °C.<sup>2</sup> For trichloroethylene (TCE), a continuous desorption study<sup>10</sup> of long-contaminated soils revealed persistence of 18% of the initial TCE concentration after desorption with 24 000 pore volumes of water. In a subsequent study<sup>3</sup> on simultaneous desorption of TCE, tetrachloroethylene, toluene, and xylene, a substantial portion (48–94%) of the sorbed contaminant mass resisted desorption after 7 days of contact time. TCE soil concentrations at the Picatinny

Arsenal were found to be 1–3 orders of magnitude greater than predicted using soil–gas concentrations and equilibrium conditions.<sup>18</sup> The present study found that the purge-and-trap method, as compared to hot solvent extraction, recovered only 42 and 4.8%, respectively, of TCE in long-contaminated clays and silty loam soils.

Even in freshly spiked soils, desorption rates of pollutants can be 1–3 orders of magnitude smaller than equilibrium-predicted rates.<sup>4</sup> Clean soils spiked with halogenated aliphatic hydrocarbons for 24–72 h resisted desorption after 16 extractions of 24–72 h each.<sup>6</sup> These observations bring into question the occurrence of desorption equilibrium necessary for validity of the purge-and-trap measurements in the freshly spiked and aged soils.

Previous analysis of EDB in long-contaminated soils has shown that purge-and-trap is less effective than extraction at 75 °C with organic solvents such as methanol, acetonitrile, and acetone.<sup>2,6,8</sup> Recovering less than 11% of the total EDB found by hot solvent extraction.<sup>8</sup> Our purpose in the present study was to extend these results to a larger class of VOCs in aged field samples. Hot methanol extraction proved to be more effective than the EPA-approved purge-and-trap technique. For three long-contaminated soils containing such VOCs as trichloroethylene, benzene, toluene, chloroform, methylene chloride, and *cis*-1,1-dichloroethylene, recovery from purge-and-trap ranged from 1.5 up to 41% that of hot methanol extraction.

Slow desorption is recognized as a serious obstacle to soil remediation technologies.<sup>11,14,20–22</sup> For such technologies as pump-and-treat, vapor extraction, and bioremediation to be effective, soil contaminants must be accessible. To simulate the effect of vapor extraction on the efficiency of the purge-and-trap methodology, we subjected the Louisiana soil to a week of air stripping. Purge-and-trap recovered only 58% of the methylene chloride, 4.1% of the *cis*-1,1-dichloroethylene, and 5.6% of the TCE that hot methanol extraction was able to recover. These results indicate that the purge-and-trap method is not a reliable method for evaluating vapor extraction as a remediation technology.

It is clear from the results of this and previous studies that the best overall choice for measurement of soil VOCs is hot methanol extraction, since this method yields a more accurate analysis, regardless of the age of contaminated soil. The VOC data from three different soil types clearly demonstrate the limitations of the EPA-approved purge-and-trap method, which can bias analytical results by several orders of magnitude, depending on soil type and chemical properties. We suggest that the EPA review the use of purge-and-trap as a method for measuring VOCs in soils.

#### ACKNOWLEDGMENT

Oak Ridge National Laboratory is managed by Lockheed Martin Energy Research Corp. for the U.S. Department of Energy under Contract DE-AC05-96OR22464.

Received for review January 3, 1996. Accepted June 17, 1996.\*

AC960009C

\* Abstract published in *Advance ACS Abstracts*, August 1, 1996.

- (14) Hatzinger, P. B.; Alexander, M. *Environ. Sci. Technol.* 1995, 29, 537–545.
- (15) Pignatello, J. J.; Ferrandino, F. J.; Huang, L. Q. *Environ. Sci. Technol.* 1993, 27, 1563–1571.
- (16) Brusseau, M. L.; Jessup, R. E.; Rao, P. S. C. *Environ. Sci. Technol.* 1991, 25, 134–142.
- (17) Wu, S. C.; Gschwend, P. M. *Environ. Sci. Technol.* 1986, 20, 717–725.
- (18) Smith, J. A.; Chiou, C. T.; Krammer, J. A.; Kile, D. E. *Environ. Sci. Technol.* 1990, 24, 676–683.
- (19) Mackay, D. M.; Cherry, J. A. *Environ. Sci. Technol.* 1989, 23, 630–636.
- (20) Di Toro, D. M.; Horzempa, L. M. *Environ. Sci. Technol.* 1982, 16, 594–602.
- (21) Coates, J. T.; Elzerman, A. W. *J. Contamin. Hydrol.* 1986, 1, 191–210.
- (22) Pignatello, J. J.; Huang, L. Q. *J. Environ. Qual.* 1991, 20, 222–228.
- (23) Scribner, S. L.; Benzing, T. R.; Sun, S.; Boyd, S. A. *J. Environ. Qual.* 1992, 21, 115–120.
- (24) Test methods for evaluating solid waste. EPA/600-SW-846, 3rd ed.
- (25) Hewitt, A. D. Cold Regions Research and Engineering Laboratory. Special Report No. 93-5, May 1993.

# GC ACCESSORIES

## 10 Position Method 5030 Purge & Trap Autosampler Retrofit

The purge & trap autosampler retrofit kit contains everything you need to add a 10 Position Method 5030 Purge & Trap Autosampler to your existing SRI purge & trap equipped GC. The kit includes a new purge & trap cover plate (A), a transfer line to valve connection (B), and a purge gas line (C).

### A. Purge & trap cover plate:

1. Remove the existing purge & trap cover plate from the GC by unscrewing the four thumbscrews that hold it in place.
2. Remove the fan from the existing purge & trap cover by unscrewing the four securing philips head screws and unplugging its white plastic 2-wire connector. Transfer the fan and its four screws to the new cover.
3. Attach the new purge & trap cover to the GC with the four screws from the old cover and re-connect the fan power.
4. Feed the autosampler's red heat transfer line through its cover plate hole, then secure it with the hose clamp included with the autosampler.

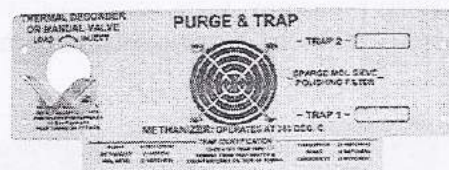

### B. Transfer line to valve connection:

1. Remove the valve oven lid by unscrewing the brass thumbscrew on the front edge of the lid, tilting the front of the lid up, then sliding back slightly to free it from the screw in the back. Carefully remove the white insulation padding, and set it securely aside with the oven lid.
2. Connect the Valco fitting to PORT #2 of the gas sampling valve (the Valco fitting is labeled "CONNECT TO PORT #2").
3. Feed the transfer line completely through the Swagelok fitting and 1/16" tubing (this fitting is labeled "INSERT X-FER LINE").
4. Use a wrench to securely tighten the fitting until it is snug against the graphite ferrule; do not over-tighten.

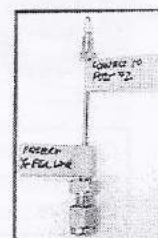

### C. Purge gas line:

1. Remove the glass test tube from the purge & trap.
2. Connect the brass union on the purge gas line to the purge gas tube (formerly inside the glass test tube). The durable Teflon™ ferrule in the brass union allows this operation to be performed many times.
3. Connect the 1/8" nut on the purge gas line to "PURGE IN" on the autosampler.

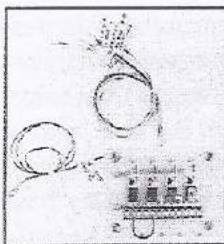
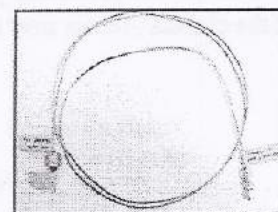

See the SRI manual for relay board installation instructions: "AUTOSAMPLERS; Installation of the Relay Board for the 10 Position Method 5030 Purge & Trap Autosampler (and other Autosamplers)"

# AUTOSAMPLERS

## Installation of the Relay Board for the 10 Position Method 5030 Purge & Trap Autosampler (and other Autosamplers)

A relay board is provided with the autosampler for connecting it to an SRI 8610 GC. This relay board supplies the additional relays required to operate the autosampler, and must be installed inside the GC by the user. The relay board comes with the necessary wiring, and no soldering is required.

The four holes in the right side panel of the GC chassis, under the "Relay Functions" table, correspond with the relay board securing screws. The relay board is installed on the inside of this panel.

4 holes for Relay Board screws

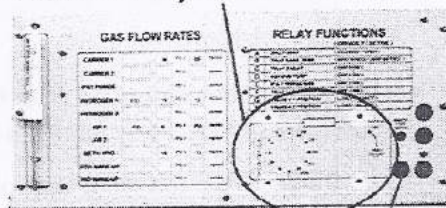

Hole for autosampler control cable

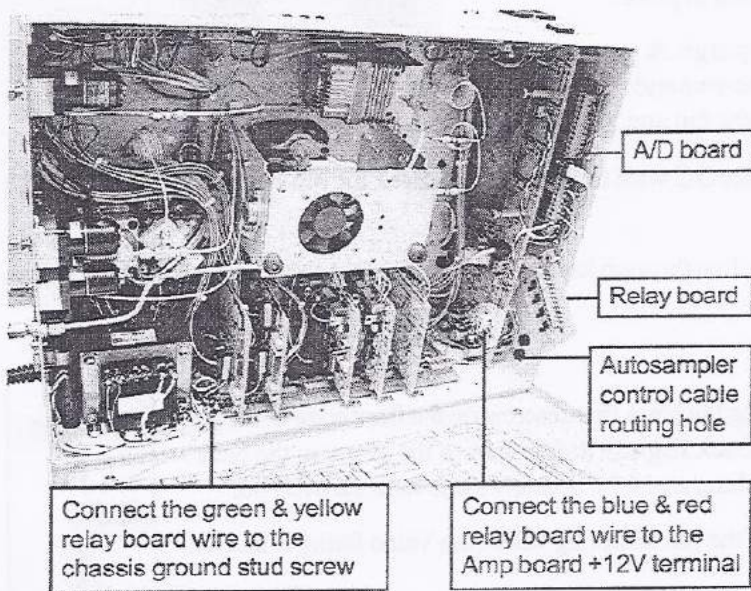

1. Remove the six screws holding the bottom panel on the GC chassis. Support the panel while you gently rock the GC onto its back, then lower the panel to your working surface to access the chassis interior.

2. Secure the four aluminum stand-offs in the relay board holes. Use the four hex-head screws provided, and secure the stand-offs from the outside of the

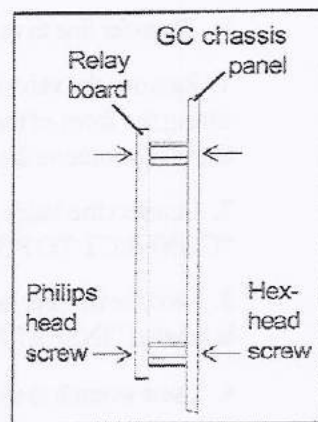

GC panel. Insert the relay board into position so that the component side faces outward. Secure it in place on the aluminum stand-offs with the four philips head screws provided.

3. Connect the green and yellow wire to the chassis ground stud screw on the left rear of the chassis interior near the main power transformer.

4. Connect each of the four yellow wires, differentiated by color stripes, to the appropriate TTL relay outputs on the A/D (Lawson) board. All eight of the TTL outputs are identical; use any available ones. Connect the blue and red wire to the Amp board 12V terminal.

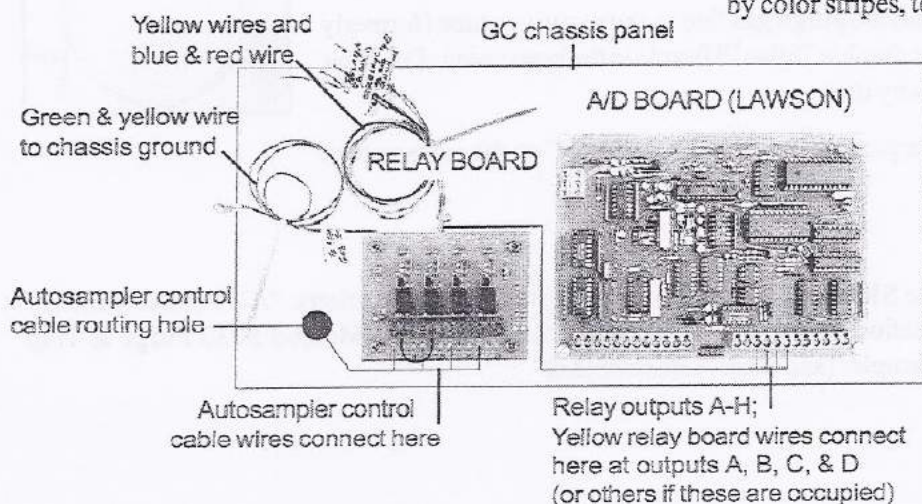

5. Remove one of the plastic hole plugs for the autosampler control cable. Route the control cable through the hole, and connect each wire to the appropriate relay circuit on the relay board (see autosampler control cable labeling).



The SRI 10 Station Purge-and-Trap Autosampler permits the unattended sparge, concentration, and analysis of up to 10 separate water and / or soil-in-water samples, when used in conjunction with the SRI EPA-Style Automated Purge-and-Trap Sample Concentrator option available as a built-in option for all SRI 8610C gas chromatographs. The PeakSimple data system (or other data system offering timed event control of external events via relays) is required for automated operation of this

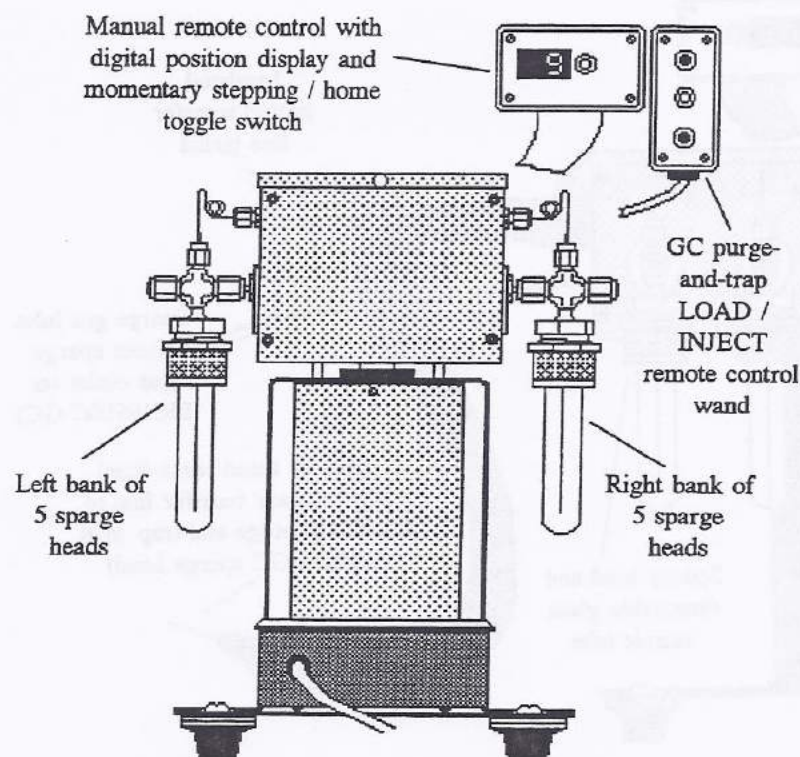

10 STATION PURGE-AND-TRAP AUTOSAMPLER SIDE VIEW

system. Manual controls are also provided for direct, manual control by the analyst, including a remote cabled sample position stepping control that features a digital LED display of the sample position in use. The toggle switch on this control has two momentary-on positions. Pushing the toggle switch to the up momentary-on position causes the automated sample stream selection valve to step to the next sample in order. Pushing the toggle switch down causes the sampling valve to return to the home (sample sparge head 1) position. The sample sparge heads are numbered according to their sampling order. A stainless steel knurled fitting holds the disposable glass sample tubes in place. Teflon ferrules in the knurled fitting seal the sample tubes in place, preventing gas leaks.

Only two gas connections are needed to supply the autosampler with sparging gas, and to deliver the sample-laden sparge gas to the purge-and-trap sampler's dual trap concentration system. These two gas lines replace the sparge head assembly on the EPA-style purge-and-trap system. A remote control signal cable connects the autosampler valve control electronics to the data system external event control circuitry. This simple cable requires only three connections to the data system event control relays, common, step, and home. The data system must provide a momentary closure between the common wire and one of the two action wires to move the stream selection valve to the desired position.

Any of the 10 sample vessels may also be used to contain a clean water blank (or air) for use between analyses for blank runs. The stream selection valve must be stepped to this blank position, and then to the desired sample position for blank operation. A large volume headspace sample may also be introduced into the system for concentration onto the dual adsorbent traps, as each sparge head is equipped with a gas injection port for manual syringe injections. In this manner, a 50cc, 100cc, or larger volume headspace sample can be passed through the traps, in order to achieve low sample detection levels unattainable by regular headspace injection on-column using standard microliter to milliliter volumes. The sparge gas supply should be turned on to assist the injected sample to flow through the traps when this feature is used.

As illustrated below, the SRI 10 Station Purge-and-Trap Autosampler is configured in a symmetrical, space-saving bilateral design. Located along each side of the unit are 5 sparge heads with respective headspace injection ports. The autosampler should be located to the left side of the SRI 8610C GC for ease of operation and access to the sample tubes. The gas transfer lines provided with the autosampler permit separation between the autosampler and GC of up to 24 inches. This

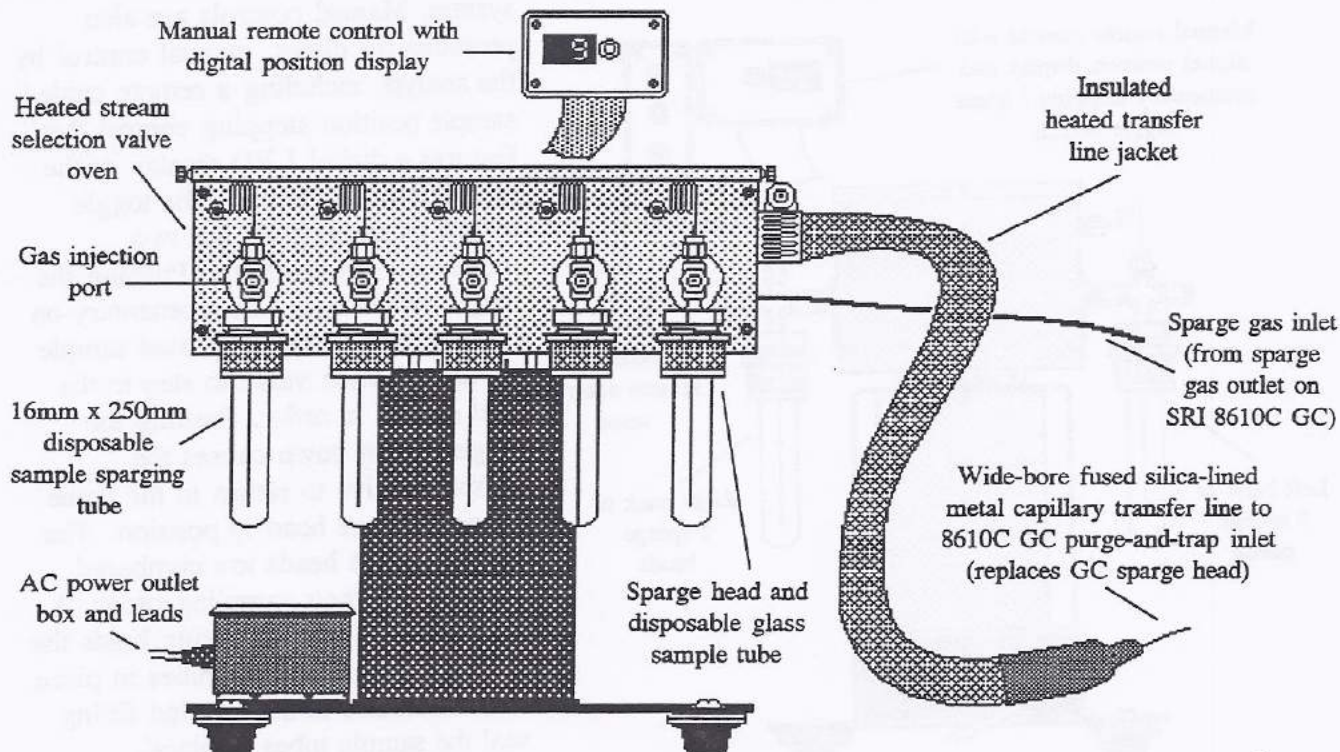

SRI 10 STATION PURGE-AND-TRAP AUTOSAMPLER FRONT VIEW

allows the analyst to have access to each sample sparging head and injection port, and to move the autosampler around on the lab bench as needed, while maintaining all connections and operability. As the autosampler is a stand-alone unit, it does not require a hard attachment or bracket for GC mounting. A 3' length of 1/16" stainless steel tubing carries the sparge gas from the GC's EPA-Style Purge-and-Trap Sampler sparge gas outlet (previously supplying gas to the single sparge head), and an insulated, electrically-heated capillary transfer line returns the sample-laden gas to the purge-and-trap system's dual adsorbent traps via the GC-mounted purge-and-trap plumbing and sampling valve hardware. The glass sample tubes are low-cost disposable 16mm x 250mm (20cc) straight-mouthed test tubes available in bulk packs from SRI or any laboratory supplier. The sparge head assemblies are stainless steel hardware that is heated by the valve oven that they are mounted to, eliminating cold metal condensation of sparged analytes. The bilateral configuration of sparge heads with respect to the stream selection valve, located inside the heated, insulated valve oven, permits the use of the minimum amount of valve plumbing. This ensures efficient and complete transfer of sample-laden gas through the autosampler system, for delivery to the GC and purge-and-trap concentrator. The headspace gas injection ports use the same 1/8" molded silicon septa that are used in the GC's direct on-column injector, minimizing the need to maintain a variety of consumable replacement parts. Unlike the on-column injector, the headspace injection ports accept needle sizes larger than 26 gauge, such as those commonly found on large volume gas sampling syringes.

The physical appearance and configuration of the 10-station purge-and-trap is subject to change without notice due to continuing improvements in hardware design

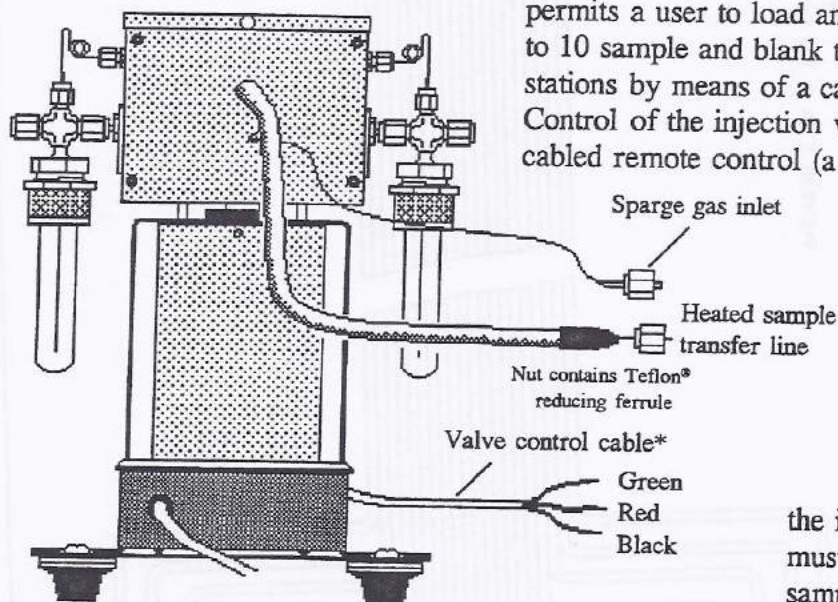

SIDE VIEW SHOWING CONNECTIONS

\* for information regarding rainbow ribbon cable used for remote control station selection, see INJECTOR & GAS VALVE section of this manual.

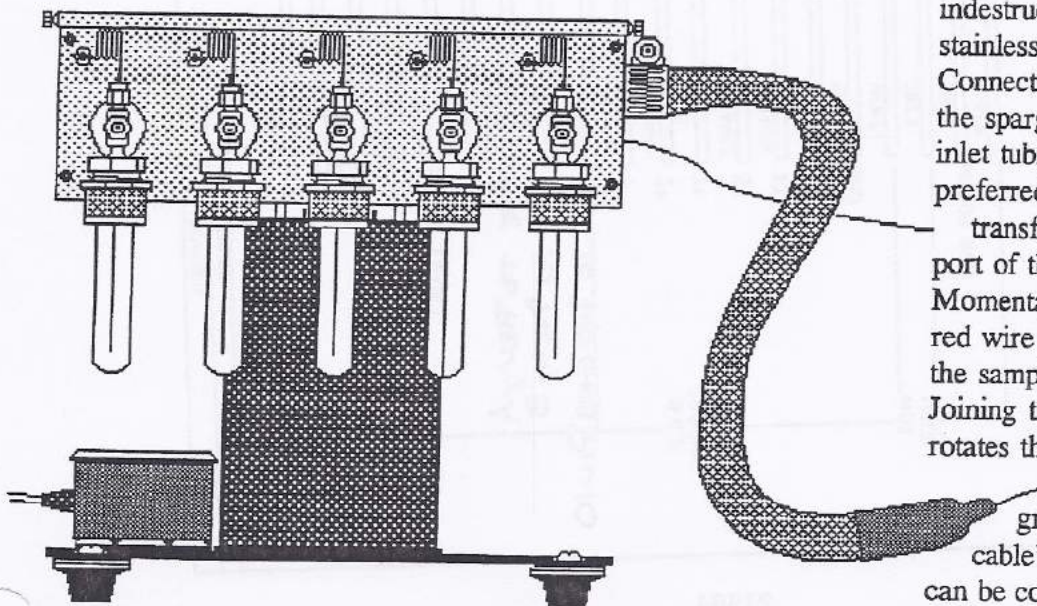

FRONT VIEW OF 10-STATION PURGE-AND-TRAP AUTOSAMPLER

The SRI 10-station purge and trap autosampler option for the SRI gas chromatograph is a free-standing purge and trap system that may be connected to any purge-and-trap concentrator-equipped brand of gas chromatograph in a matter of minutes. The system permits a user to load and sparge any combination of up to 10 sample and blank test tubes and select sampling stations by means of a cabled digital remote control. Control of the injection valve is performed by another cabled remote control (a three-wire cable is also provided

to permit relay switching under data system or integrator control). The system includes a heated valve oven that prevents any condensation of analyte in the valves or adjacent plumbing. The sparging heads are also maintained warm to prevent adhesion of sample on

the interior surfaces. A transfer line must be used in order to move the sample analytes from the valve oven to the injection port or sampling valve of the host chromatograph. A built-in heating element prevents sample analyte from condensing in the line, actually 36" of virtually indestructible, fused-silica lined stainless steel capillary tubing.

Connections are as follows: connect the sparge gas supply to sparge gas inlet tubing. 5psi of helium is preferred. Connect the heated

transfer line to the sparge head port of the purge-and-trap system. Momentary connection of green and red wire of three-wire cable rotates the sampling valve to LOAD. Joining the green and black wires rotates the sampling valve to the

INJECT position. The green wire is the control cable's GROUND. These wires can be connected to data system

relays or other switches. Plug the power cables into an AC outlet and allow the system to warm up. It is now ready for use.

- NOTE:
1. ALL INPUTS ARE 5 VOLT NEGATIVE TRUE LOGIC.
  2. B.C.D. POSITION OUTPUTS ARE CAPABLE OF 10 MILLIAMPERES. MAX. OUTPUT
  3. INPUTS REQUIRE .5 MILLIAMPERES DRIVE.

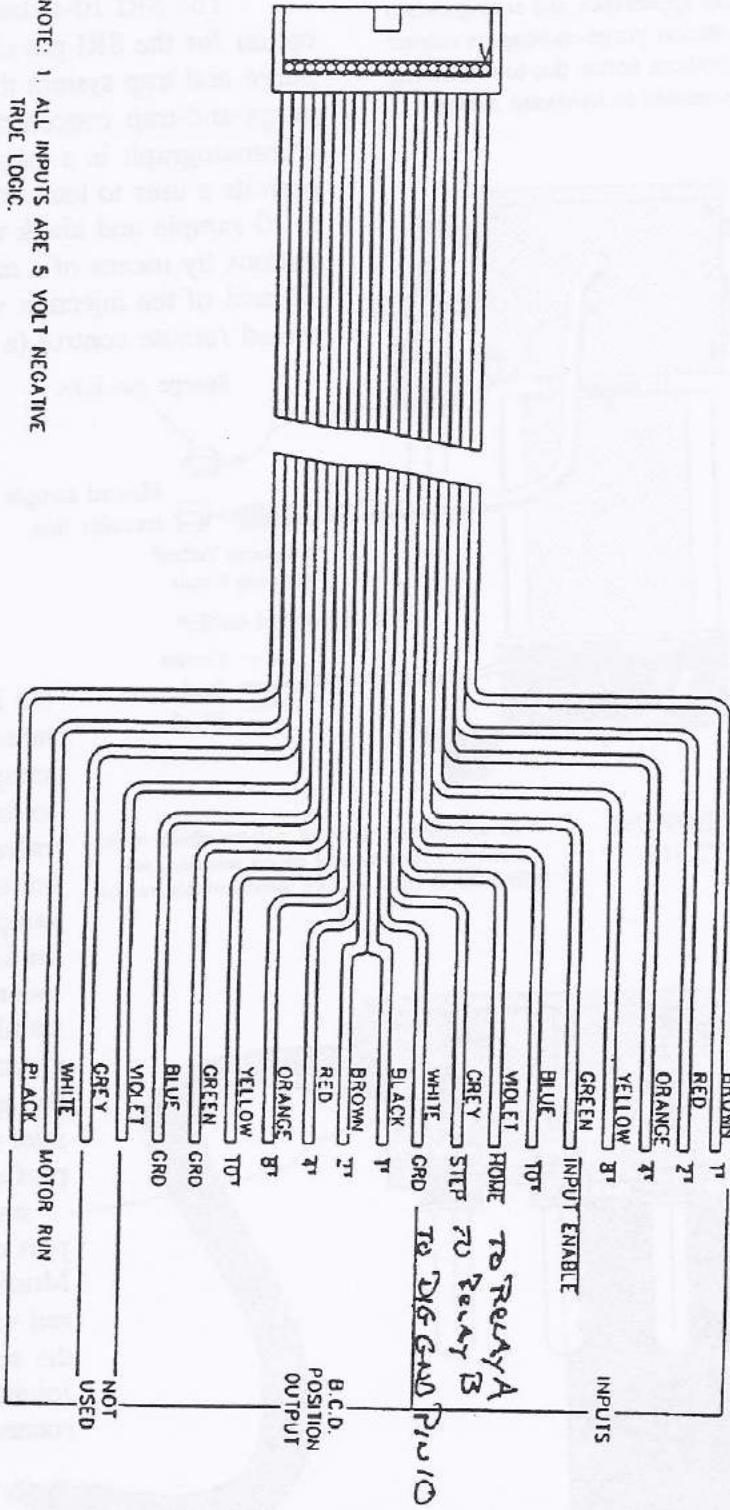

REVISIONS		
LM	DESCRIPTION	DATE

NEXT ASSY		B-21421.21575	
YEAR \		ICCMPEA	
Volco Instruments Co., Inc.			
INTERFACE CABLE CONN.			
MULTI POS. ELE. ACT.			
SCALE	SITE	DRAWING NO.	
	B	21464	
DO NOT SCALE DRAWING			
SWGT			

The on-line liquid sampler accessory for the SRI purge-and-trap sampling system is an external unit designed to deliver, purge, and evacuate a liquid sample from the SRI purge-and-trap sample concentrator, on a repetitive basis, under data system automation. This permits the unattended monitoring of any fluid effluent or stream on a continuous basis. In order to operate this accessory, the following installation steps are required:

1. Locate the three cables exiting the rear of the on-line liquid sampler. Find and connect the AC supply cable to an available AC wall outlet. A second cable terminates in a remote control wand for the optional manual operation of the liquid sampling valve. Operation of this control is by means of the toggle switch provided. Make sure that the valve is in the LOAD position before proceeding. The third cable is the control cable for the sampling valve actuator. Of the 5 wires in this cable, only three are used (green, black, and red) for control of the valve loading and injection. Connect these wires to an unused relay (or relays) in your data system (green is common).
2. Four ports are located on the front panel of the on-line liquid sampler. The upper left port is the liquid sample inlet, where the incoming sample flow is connected. The lower left port is the sample outlet for liquid that has passed through the 5cc sampling loop to the drain line. Route the drain away from the GC and any electrical devices and connections. The upper right port is the sparge gas inlet. Disconnect the sparge gas supply line from the GC to the original purge-and-trap sparge head, and connect it here. The lower right port is the sparge gas outlet from the internal liquid sampling valve. This outlet is directed to the inlet of the modified sparging head provided with this unit.
3. Remove the original purge-and-trap sparging head from the GC purge-and-trap sampler, and replace it with the sparging head provided with the on-line liquid sampler. Note that it is equipped with two lines that enter the sparge head through the top. One line delivers the liquid sample, propelled by the flow of sparge gas through the liquid sampling valve. The second line is the drain line that carries spent sample from the sparging head to the drain line, after passing through a solenoid-controlled valve that controls draining.

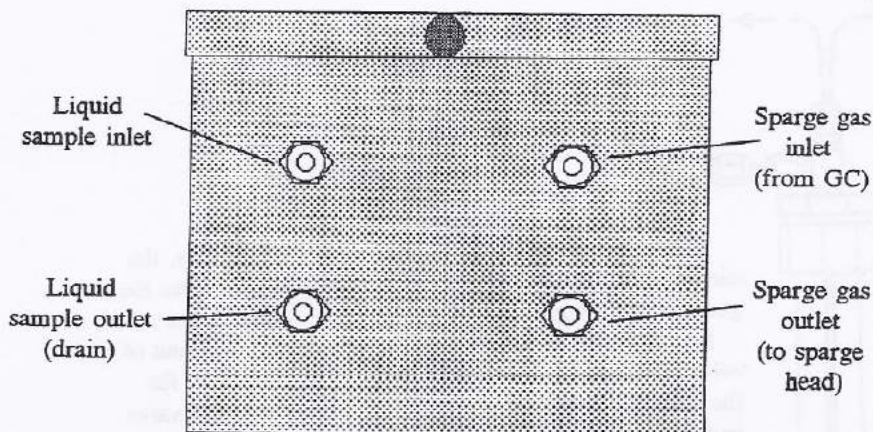

FRONT VIEW OF ON-LINE LIQUID SAMPLER ACCESSORY

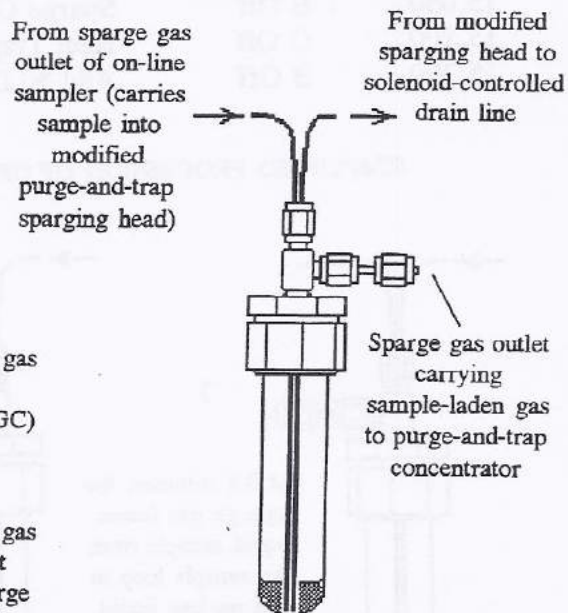

MODIFIED SPARGE HEAD FOR PURGE-AND-TRAP SAMPLER

4. Once the on-line sampling accessory hardware has been connected to the SRI purge-and-trap sampling system, edit the purge-and-trap timed event table in order to control the on-line sampler as an integral part of the purge-and-trap system. The event table used should be similar to the timed event table that follows, making note that events H and D specifically control the liquid sampling valve rotation and the sparge head drain valve, respectively. Once the event table has been input and saved, the system is ready for operation.

#### TIMED EVENT TABLE FOR ON-LINE LIQUID SAMPLING ACCESSORY

TIME	EVENT	DESCRIPTION
0.100	E On	Sparge Gas Activation (Gas On)
0.200	H On	Rotate Liquid Sampling Valve To INJECT Position
4.500	D On	Sparge Head Drain Valve Open To Drain
5.100	E Off	Sparge Gas Activation (Gas Off)
5.300	D Off	Sparge Head Drain Valve Closed
5.400	H Off	Rotate Liquid Sampling Valve To LOAD Position
6.000	C On	Heat Trap #2
6.100	F On	Heat Trap #1
8.000	G On	Rotate Purge-and-Trap Sampling Valve To INJECT Position
12.000	E On	Sparge Gas Activation (Gas On)
13.000	G Off	Rotate Purge-and-Trap Sampling Valve To LOAD Position
13.100	B On	Add 50 Degrees To Trap Temperature Setpoint (For Bakeout)
14.900	F Off	Heat Trap #1(Heat Off)
15.050	E Off	Sparge Gas Activation (Gas Off)
15.100	C Off	Heat Trap #2 (Heat Off)
15.200	B Off	Add 50 Degrees To Trap Temperature Setpoint (Back To Normal)

#### SIMPLIFIED PROCESSION OF OPERATION - ON-LINE LIQUID SAMPLING ACCESSORY

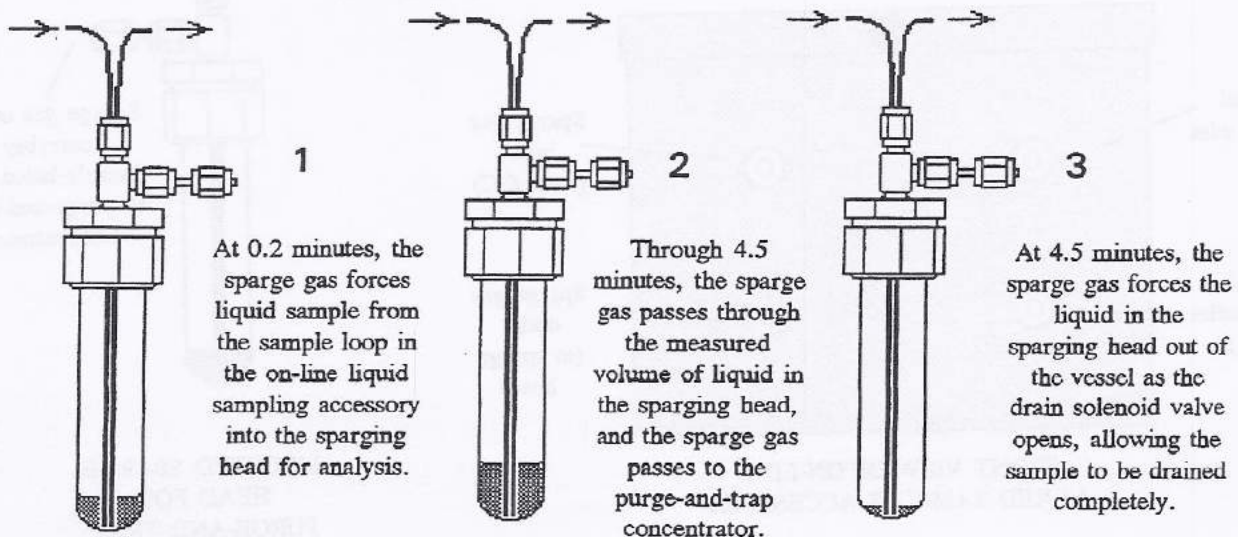

# Stream Flow using Standard Vacuum Pump

3/16/03

1/8" Tubing	
Length (ft)	Flow (mL/min)
50	570
100	420
150	240
200	150
250	80
300	60

The flow was measured from the exit port of a standard Rena Vacuum Pump.

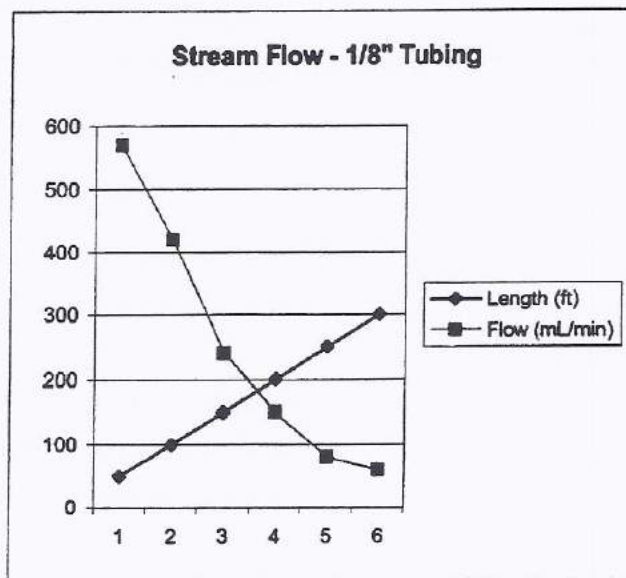

# INJECTORS

## Heated Static Headspace Injector

### Overview

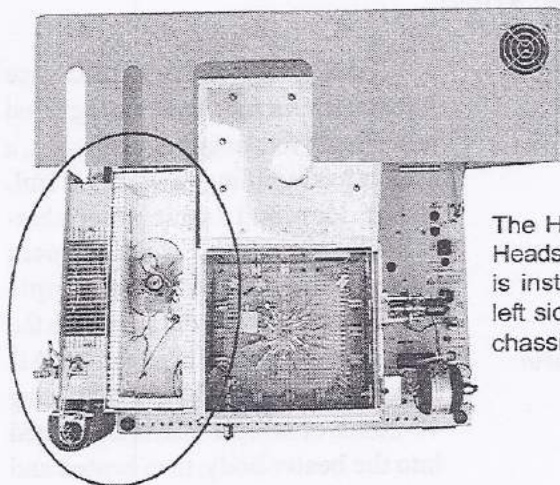

The Heated Static Headspace Injector is installed on the left side of the GC chassis

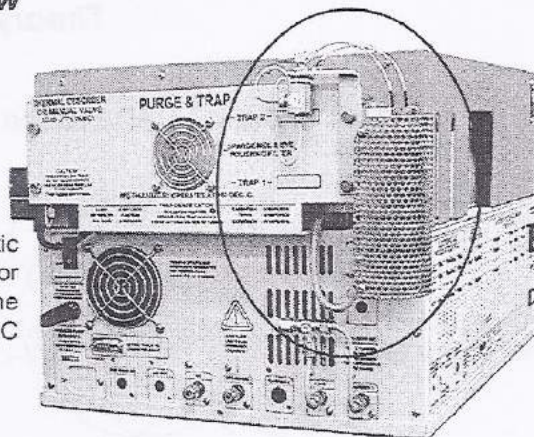

The Heated Static Headspace Injector is useful for analysis of the light volatiles that can be partitioned into the headspace of a vial containing either a liquid or a solid matrix sample. It can be used with dirty or complex samples, such as blood, urine, powders, foods and flavors. The SRI Heated Static Headspace Injector is built into the 8610C GC, on the left side of the chassis, eliminating the need for transfer lines and reducing dead volume. Thermostatted from ambient to 90°C, a heater body accepts a 40mL VOA vial containing 10-20mL of sample. Covered with a protective heat shield, the heater body is heated and mechanically agitated under control of the PeakSimple data system. Two needles puncture the vial's septum top upon insertion into the heater body. Purge gas to pressurize the vial is delivered through one needle. The other needle carries the headspace vapors to the sample loop on the 10 port gas sampling valve, located in the valve oven. On the downstream end of the loop is a solenoid shut-off valve, also controlled through the data system. This solenoid shut-off valve opens to fill the sample loop with the sample headspace from the pressurized vial. A syringe port allows the addition of internal standards, spikes, etc. into the vial without exposing the sample to ambient air.

### Heated Static Headspace Injector

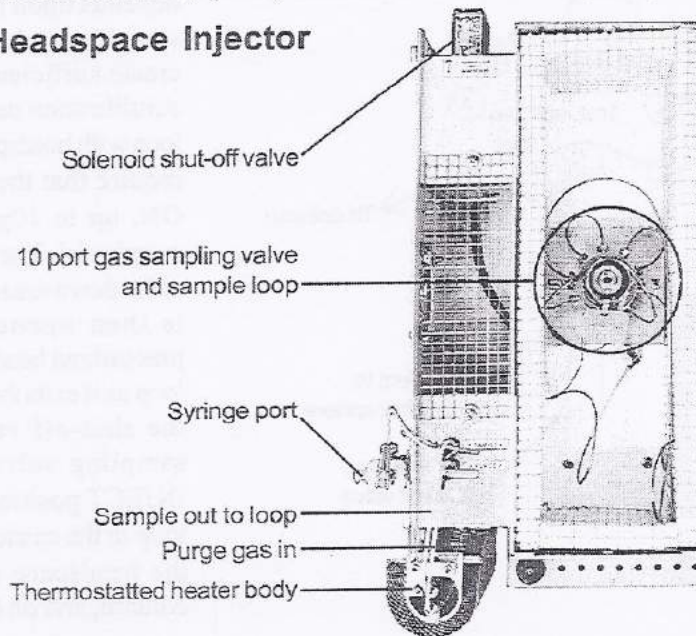



# INJECTORS

## Heated Static Headspace Injector

### Theory of Operation

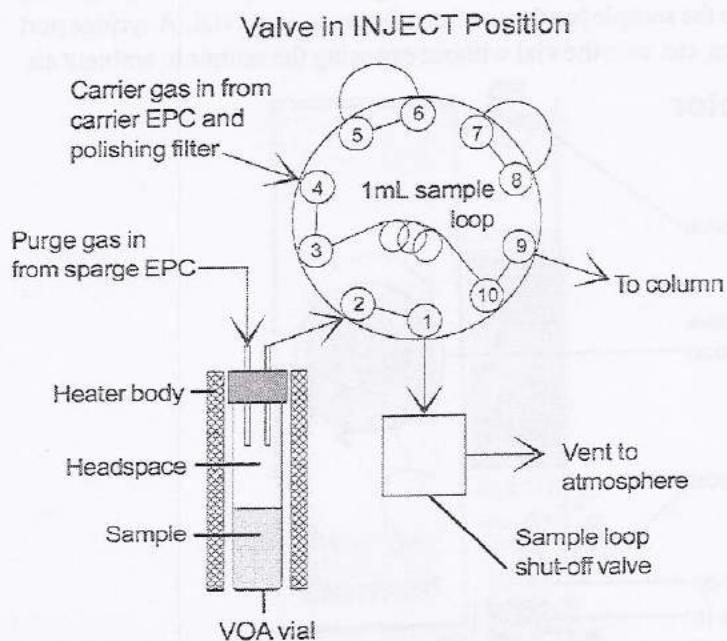
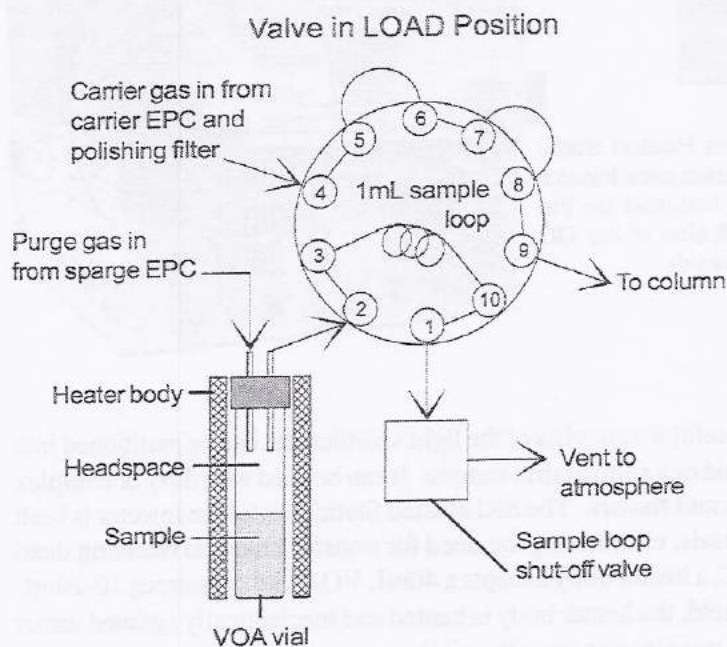

The SRI Heated Static Headspace Injector uses a mechanically agitated heater body for sample equilibration, a 10 port gas sampling valve with a 1mL sample loop, and a sample loop shut-off solenoid valve. The headspace analysis begins with the sample equilibration period, during which the gas sampling valve is in the LOAD position. A 40mL VOA vial containing 10-20mL of sample matrix is inserted into the heater body, then heated and agitated (the time it takes to achieve equilibration depends on the sample matrix and the target analytes). Two needles in the upper part of the heater body puncture the septum top of the vial in order to deliver purge gas into and route the sample out of the vial. After the equilibration period, the vial is pressurized so that the sample will escape when the solenoid shut-off valve is opened. The amount of purge gas needed to pressurize the VOA vial depends upon the type of sample. A sample with high liquid content can create sufficient pressure during the equilibration period to fill the sample loop with headspace. A dry sample will require that the purge gas be turned ON, up to 10psi, to pressurize the sample vial. The solenoid shut-off valve at the downstream end of the 1mL loop is then opened briefly, and the pressurized headspace sample fills the loop as it exits through the valve. After the shut-off valve closes, the gas sampling valve is actuated to the INJECT position, placing the sample loop in the carrier gas stream to sweep the headspace sample into the GC column, and on to the detector(s).

# INJECTORS

## Heated Static Headspace Injector

### General Operating Procedures

1. The Headspace injection technique requires little sample preparation, since just the sample headspace, not the sample itself, is run through the GC. Insert 10-20mL of sample into a clean VOA vial and seal it.

2. The purge gas pressure is controlled with an Electronic Pressure Controller (EPC). Set the purge gas to 0-10psi, depending on the liquid content of the sample. SRI recommends helium purge gas.

3. Using the trimpot on the top edge of the GC's front control panel, set the heater body temperature between ambient and 90°C. Pressure builds as the vial is heated. The temperature setting depends upon the target analytes and the liquid content of the sample.

4. Create or load an event table. **Hdspace.evt**, shown at right and on the **Expected Performance** page, is included in version 2.66 (and higher) of the PeakSimple software. A typical event table heats and agitates the vial for 20 minutes; it may take more or less time to achieve headspace equilibration.

5. Create or load a temperature program. The column oven is typically held at the initial temperature (usually 40°C) for the duration of the sample equilibration period, plus 2-4 more minutes.

6. Set the valve oven temperature to 100°C or higher to avoid water condensation (120°C is a typical setting).

7. Activate and energize your detectors as necessary. Consult the manual sections for your particular detector(s).

8. Insert a VOA vial filled with 10-20mL of sample into the headspace heater body: slide the vial into the heater body from the bottom. You will feel some resistance as the needles meet the vial septum lid, and once the needles have penetrated the septum, the vial will stop against the top of the heater body interior. The needles will hold the vial in place. Begin the analysis by pressing the RUN button on the GC or the spacebar on your computer keyboard.

Hdspace.evt		
EVENT TIME	EVENT	EVENT FUNCTION
0.000	ZERO	Zero signal
0.100	F "ON"	VOA Vial Heater
0.200	D "ON"	Shaker solenoid "ON"
19.400	D "OFF"	Shaker solenoid "OFF"
19.500	F "OFF"	VOA Vial Heater
19.600	E "ON"	Purge "ON"
19.700	E "OFF"	Purge "OFF"
19.800	A "ON"	Sample loop exit solenoid open
19.900	A "OFF"	Sample loop exit solenoid closed
20.000	G "ON"	Valve in INJECT
27.000	G "OFF"	Valve in LOAD

# INJECTORS

## Heated Static Headspace Injector

### Expected Performance

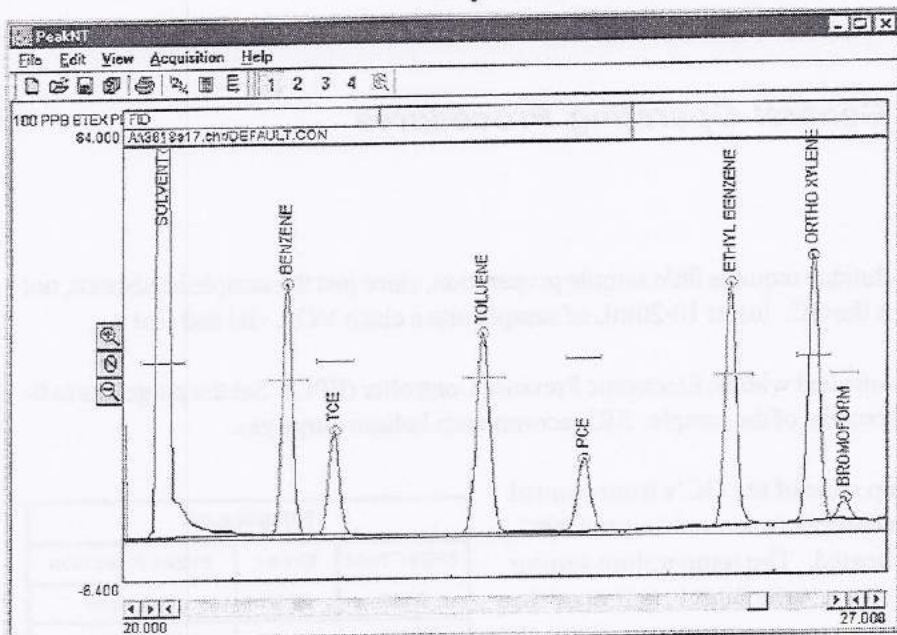

Sample: 1µL 100ppb BTEX Plus (vial 25% full of sample solution with 10µL of 100ppb BTEX Plus) VOA vial set to heat from ambient temperature to 50°C  
Column: 15m MXT-VOL  
Carrier: helium @ 10mL/min

FID gain: HIGH  
FID temp: 300°C  
FID ignitor: -400  
Valve temp: 120°C

Column oven temperature program  
(Hdspace.tem):  
Initial Hold Ramp Final  
50°C 23.00 10.00 160°C

The following two chromatograms were produced in series by an SRI GC equipped with a static headspace injector and an FID detector. The first chromatogram is a 100ppb BTEX Plus sample, and the second is a water blank. Both were run under identical conditions. Magnified for visibility, the water blank shows the carryover level of the Headspace injection system.

#### Events:

Time	Event
0.100	F ON (VOA vial heater)
0.200	D ON (shaker solenoid)
19.400	D OFF
19.500	F OFF
19.600	E ON (purge gas)
19.700	E OFF
19.800	A ON (sample loop exit solenoid)
19.900	A OFF
20.000	G ON (valve actuator)
27.000	G OFF

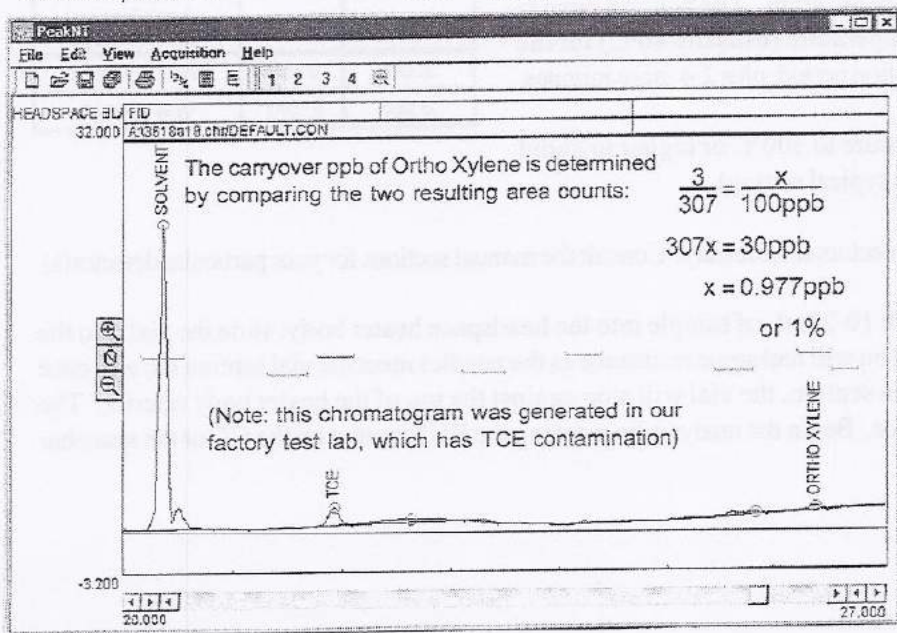

#### BTEX sample results:

Component	Retention	Area
Solvent	20.350	7332.0805
Benzene	21.483	266.2780
TCE	21.916	119.6645
Toluene	23.266	285.2310
PCE	24.216	98.6710
Ethyl Benzene	25.583	298.6540
Ortho Xylene	26.333	306.6115
Bromoform	26.616	24.4815
<b>Total</b>		<b>8731.6720</b>

#### Water blank results:

Component	Retention	Area
Solvent	20.350	137.0385
TCE	21.916	10.0770
Ortho Xylene	26.350	3.1305
<b>Total</b>		<b>150.2460</b>